

# Motor Specifications

### STANDARD RUBBER

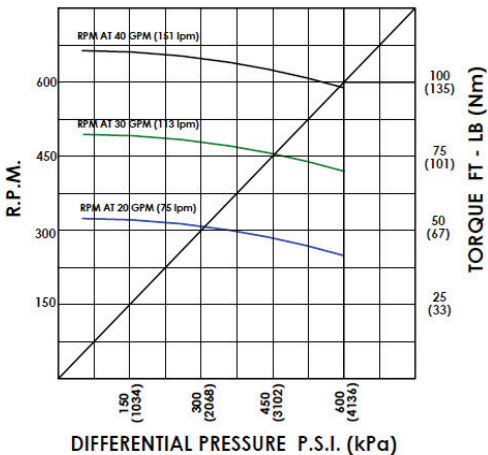

DIFFERENTIAL PRESSURE P.S.I. (kPa)

VOLUME (gpm)	20-40
SPEED (rpm)	250-660
TORQUE AT FULL LOAD (ft-lb)	100
OUTPUT AT FULL LOAD (hp)	11.2

### 1 11/16" 5 - 6 4 Stg

SEALED BEARING 22.1"  
 BIT TO BEND FIXED N/A  
 BIT TO BEND ADJ. 2700 lb.  
 MAX W.O.B. 92"  
 O/A LENGTH 72"  
 MAX. OVERPULL AND RERUN 6500 lb.  
 ABSOLUTE OVERPULL 45,000 lb.  
 TOOL SHIPPING WEIGHT 30 lb.

BIT BOX CONN. 1 MT.  
 ADJUSTABLE TORQUE N/A  
 REV/ GAL AT FULL LOAD 14.7  
 REV/ GAL AT NO LOAD 16.5

DIFF. PRES. STANDARD 600 psi  
 DIFF. PRES. HARD 900 psi

### HARD RUBBER

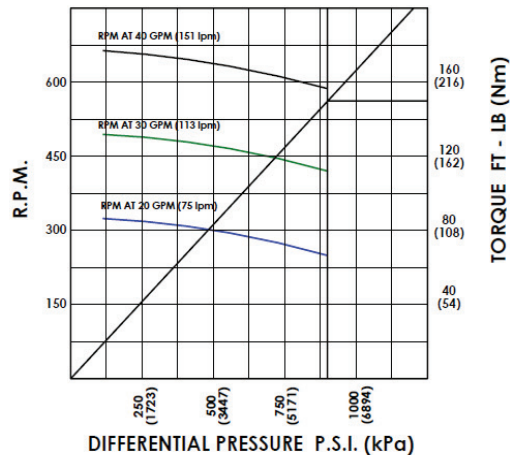

DIFFERENTIAL PRESSURE P.S.I. (kPa)

VOLUME (gpm)	20-40
SPEED (rpm)	250-660
TORQUE AT FULL LOAD (ft-lb)	150
OUTPUT AT FULL LOAD (hp)	16.8

1 11/16 5-6 4 Stg.

### STANDARD RUBBER

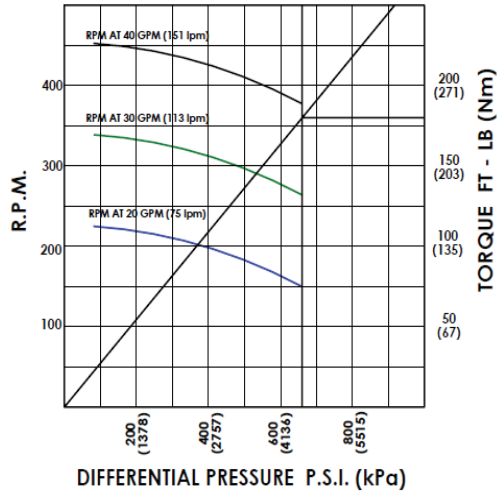

VOLUME (gpm)	20-40
SPEED (rpm)	150-450
TORQUE AT FULL LOAD (ft-lb)	180
OUTPUT AT FULL LOAD (hp)	13

### 1 11/16" 5 - 6 4.4 Stg

SEALED BEARING  
 BIT TO BEND FIXED 22.1"  
 BIT TO BEND ADJ. N/A  
 MAX W. O. S. 2700 lb.  
 O/A LENGTH 117.5"  
 MAX. OVERPULL AND RERUN 6500 lb.  
 ABSOLUTE OVERPULL 45,000 lb.  
 TOOL SHIPPING WEIGHT 30 lb.

BIT BOX CONN. 1 MT.  
 ADJUSTABLE TORQUE N/A  
 REV/ GAL AT FULL LOAD 9.42  
 REV/ GAL AT NO LOAD 11.25

DIFF. PRES. STANDARD 660 psi  
 DIFF. PRES. HARD 990 psi

### HARD RUBBER

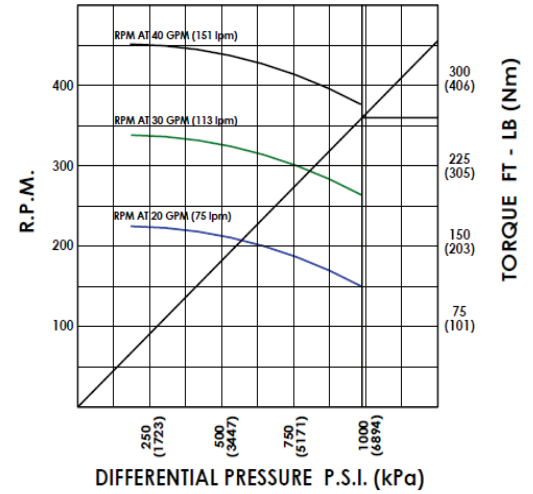

VOLUME (gpm)	20-40
SPEED (rpm)	150-450
TORQUE AT FULL LOAD (ft-lb)	270
OUTPUT AT FULL LOAD (hp)	19.5

1 11/16" 5-6 4.4 Stg.

**STANDARD RUBBER**

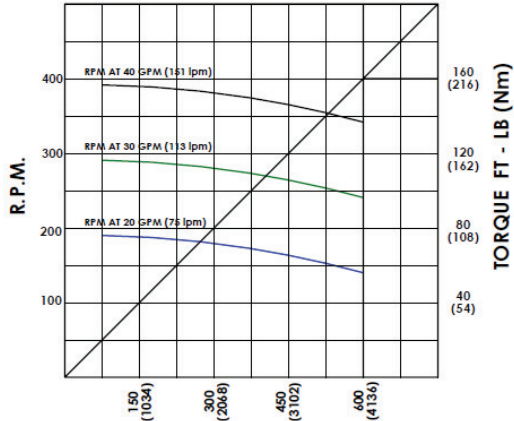

**DIFFERENTIAL PRESSURE P.S.I. (kPa)**

VOLUME (gpm)	20-40
SPEED (rpm)	190-390
TORQUE AT FULL LOAD (ft-lb)	160
OUTPUT AT FULL LOAD (hp)	10.5

**2 1/8" 5 - 6 4 Stg**

SEALED BEARING 28.1"  
 BIT TO BEND FIXED N/A  
 BIT TO BEND ADJ. 9.340 lb.  
 MAX W.O.B. 199.8"  
 O/A LENGTH 26,700 lb.  
 MAX. OVERPULL AND RERUN 78,375 lb.  
 ABSOLUTE OVERPULL 114 lb.  
 TOOL SHIPPING WEIGHT

BIT BOX CONN. 1 1/2 MT.  
 ADJUSTABLE TORQUE N/A  
 REV/ GAL AT FULL LOAD 8.52  
 REV/ GAL AT NO LOAD 9.75

DIFF. PRES. STANDARD 600 psi  
 DIFF. PRES. HARD 900 psi

**HARD RUBBER**

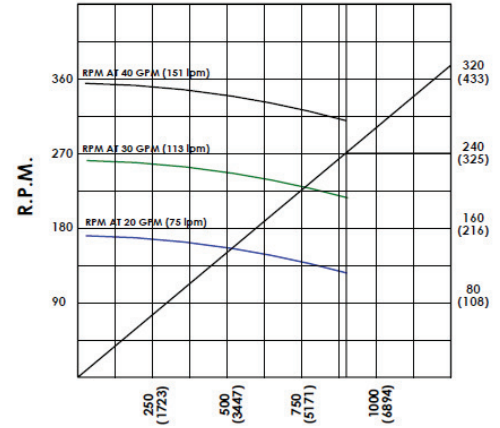

**DIFFERENTIAL PRESSURE P.S.I. (kPa)**

VOLUME (gpm)	20-40
SPEED (rpm)	190-390
TORQUE AT FULL LOAD (ft-lb)	240
OUTPUT AT FULL LOAD (hp)	15.6

**2 1/8" 5-6 4 Stg.**



**STANDARD RUBBER**

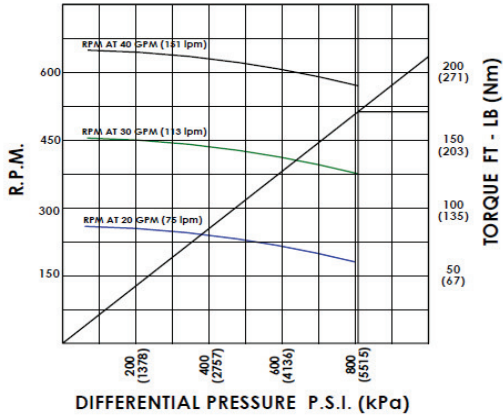

VOLUME (gpm)	20-50
SPEED (rpm)	180-650
TORQUE AT FULL LOAD (ft-lb)	171
OUTPUT AT FULL LOAD (hp)	19.1

**2 1/8" 5 - 6 6 Stg**

**SEALED BEARING**  
 BIT TO BEND FIXED 28.1"  
 BIT TO BEND ADJ. N/A  
 MAX W.O.B. 9,340 lb.  
 O/A LENGTH 221.3"  
 MAX. OVERPULL AND RERUN 26,700 lb.  
 ABSOLUTE OVERPULL 78,375 lb.  
 TOOL SHIPPING WEIGHT 120.3 lb.

**BIT BOX CONN.** 1 1/2 MT.  
 ADJUSTABLE TORQUE N/A  
 REV/ GAL AT FULL LOAD 11.76  
 REV/ GAL AT NO LOAD 12.00

**DIFF. PRES. STANDARD** 809 psi  
**DIFF. PRES. HARD** 1012 psi

**HARD RUBBER**

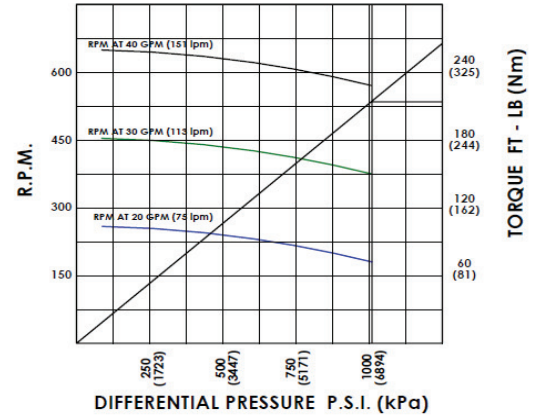

VOLUME (gpm)	20-50
SPEED (rpm)	180-650
TORQUE AT FULL LOAD (ft-lb)	214
OUTPUT AT FULL LOAD (hp)	27

**2 1/8 5-6 6 Stg.**

### STANDARD RUBBER

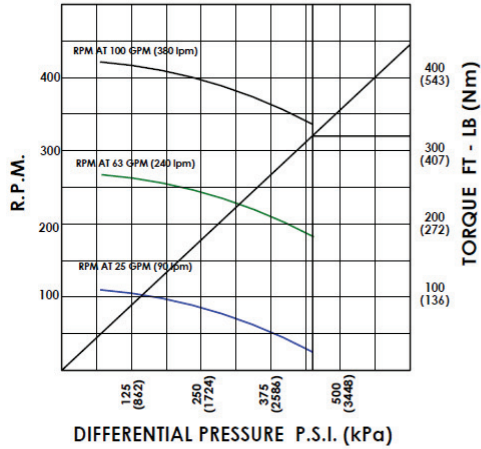

DIFFERENTIAL PRESSURE P.S.I. (kPa)

VOLUME (gpm)	25-100
SPEED (rpm)	25-420
TORQUE AT FULL LOAD (ft-lb)	320
OUTPUT AT FULL LOAD (hp)	20.5

### 2 7/8" 5 - 6 3.0 Stg

SEALED BEARING 30.3"  
 BIT TO BEND FIXED 37.3"  
 BIT TO BEND ADJ.  
 MAX W.O.B. 9,340 lb.  
 O/A LENGTH 139.7'  
 MAX. OVERPULL AND RERUN 24,700 lb.  
 ABSOLUTE OVERPULL 124,000 lb.  
 TOOL SHIPPING WEIGHT 179 lb.

HOLE SIZE 3 3/4" - 4 1/8"  
 BIT BOX CONN. 2 3/8 REG.  
 ADJUSTABLE TORQUE 2000 ft-lb  
 REV/ GAL AT FULL LOAD 3.36  
 REV/ GAL AT NO LOAD 4.20

DIFF. PRES. STANDARD 450 psi  
 DIFF. PRES. HARD 680 psi

### HARD RUBBER

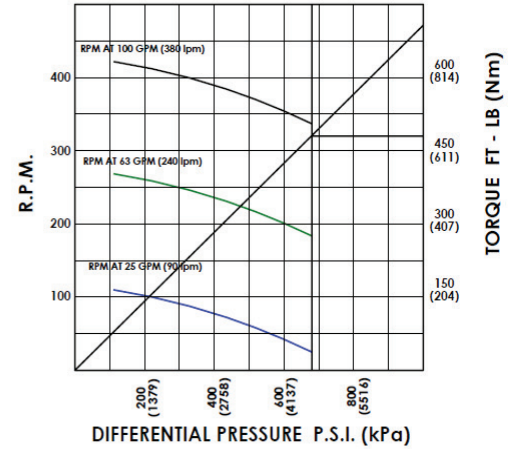

DIFFERENTIAL PRESSURE P.S.I. (kPa)

VOLUME (gpm)	25-100
SPEED (rpm)	25-420
TORQUE AT FULL LOAD (ft-lb)	480
OUTPUT AT FULL LOAD (hp)	30.8

2 7/8" 5-6 3 Stg.

### STANDARD RUBBER

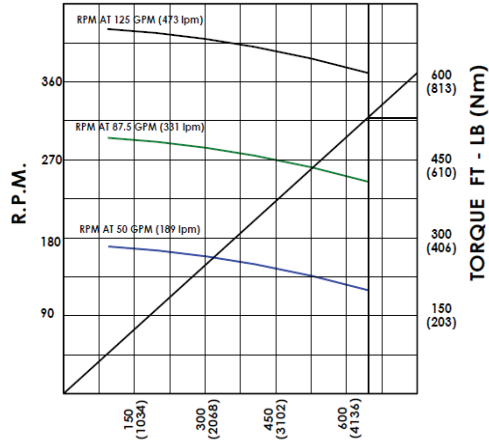

DIFFERENTIAL PRESSURE P.S.I. (kPa)

VOLUME (gpm)	50-125
SPEED (rpm)	120-420
TORQUE AT FULL LOAD (ft-lb)	532
OUTPUT AT FULL LOAD (hp)	37.6

### 2 7/8" 5 - 6 4.7 Stg

#### SEALED BEARING

BIT TO BEND FIXED 30.3"  
 BIT TO BEND ADJ. 37.3"  
 MAX W.O.B. 9,360 lb.  
 O/A LENGTH 158.4"  
 MAX. OVERPULL AND RERUN 26,700 lb.  
 ABSOLUTE OVERPULL 124,000 lb.  
 TOOL SHIPPING WEIGHT 200 lb.

HOLE SIZE 3 3/4" - 4 1/8"  
 BIT BOX CONN. 2 3/8 REG.  
 ADJUSTABLE TORQUE 2000 ft-lb  
 REV/ GAL AT FULL LOAD 2.96  
 REV/ GAL AT NO LOAD 3.36

DIFF. PRES. STANDARD 648 psi  
 DIFF. PRES. HARD 810 psi

### HARD RUBBER

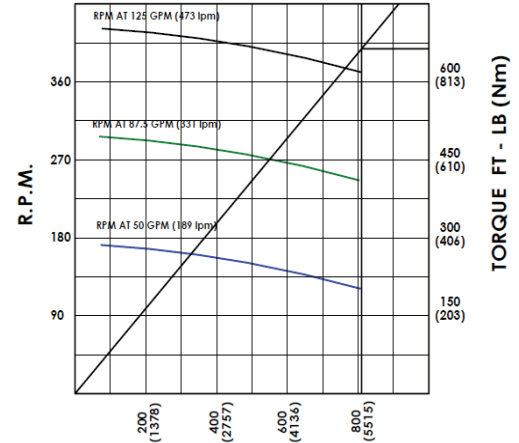

DIFFERENTIAL PRESSURE P.S.I. (kPa)

VOLUME (gpm)	50-125
SPEED (rpm)	120-420
TORQUE AT FULL LOAD (ft-lb)	665
OUTPUT AT FULL LOAD (hp)	47

2 7/8 5-6 4.7 Stg.

### STANDARD RUBBER

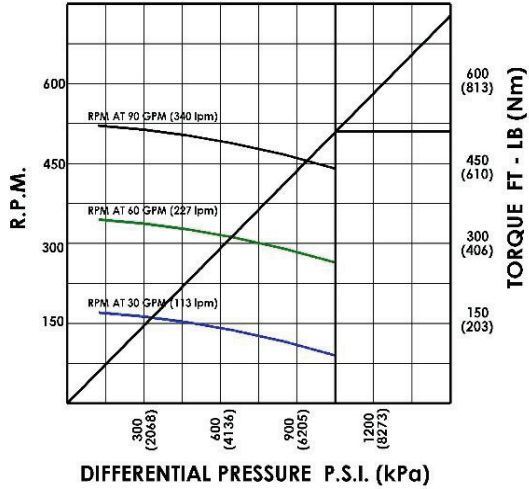

VOLUME (gpm)	30-90
SPEED (rpm)	90-520
TORQUE AT FULL LOAD (ft-lb)	510
OUTPUT AT FULL LOAD (hp)	42.7

### 2 7/8" 5 - 6 7.0 Stg

SEALED BEARING  
BIT TO BEND FIXED 30.3"  
BIT TO BEND ADJ. 37.3"  
MAX W.O.B. 9,360 lb.  
O/A LENGTH 169.8"  
MAX. OVERPULL AND RERUN 26,700 lb.  
ABSOLUTE OVERPULL 124,000 lb.  
TOOL SHIPPING WEIGHT 201 lb.

HOLE SIZE 3 3/4" - 4 1/8"  
BIT BOX CONN. 2 3/8 REG.  
ADJUSTABLE TORQUE 2000 ft-lb  
REV/ GAL AT FULL LOAD 4.88  
REV/ GAL AT NO LOAD 5.77

DIFF. PRES. STANDARD 1050 psi  
DIFF. PRES. HARD 1580 psi

### HARD RUBBER

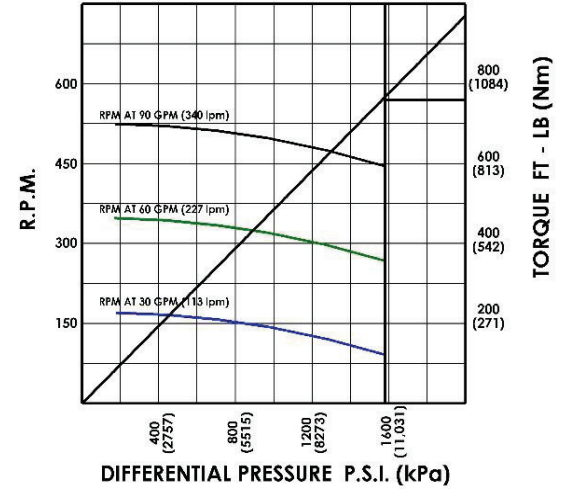

VOLUME (gpm)	30-90
SPEED (rpm)	90-520
TORQUE AT FULL LOAD (ft-lb)	760
OUTPUT AT FULL LOAD (hp)	63.7

2 7/8 5-6 7 Stg.

**STANDARD RUBBER**

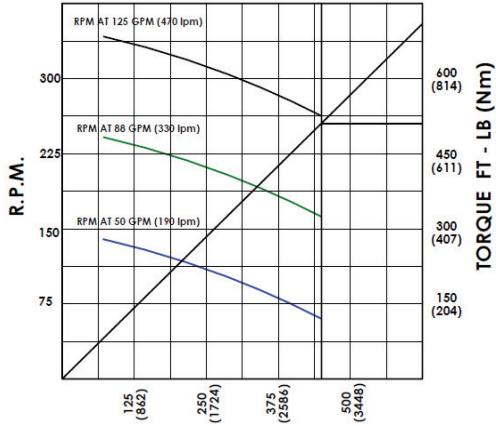

**DIFFERENTIAL PRESSURE P.S.I. (kPa)**

VOLUME (gpm)	50-125
SPEED (rpm)	60-340
TORQUE AT FULL LOAD (ft-lb)	510
OUTPUT AT FULL LOAD (hp)	25.6

**2 7/8" 7 - 8 3.0 Stg**

SEALED BEARING  
 BIT TO BEND FIXED  
 BIT TO BEND ADJ.  
 MAX. W.O.B.  
 O/A LENGTH  
 MAX. OVERPULL AND RERUN  
 ABSOLUTE OVERPULL  
 TOOL SHIPPING WEIGHT

30.3"  
 37.3"  
 9,360 lb.  
 147.1"  
 26,700 lb.  
 124,000 lb.  
 204 lb.

HOLE SIZE  
 BIT BOX CONN.  
 ADJUSTABLE TORQUE  
 REV/ GAL AT FULL LOAD  
 REV/ GAL AT NO LOAD

3 3/4" - 4 1/8"  
 2 3/8 REG.  
 2000 ft-lb  
 2.10  
 2.72

DIFF. PRES. STANDARD  
 DIFF. PRES. HARD

450 psi  
 680 psi

**HARD RUBBER**

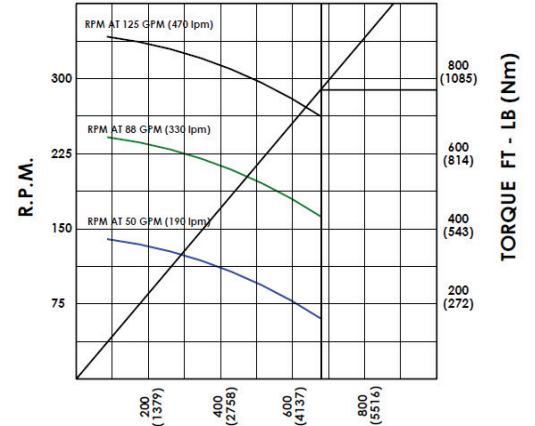

**DIFFERENTIAL PRESSURE P.S.I. (kPa)**

VOLUME (gpm)	50-125
SPEED (rpm)	60-340
TORQUE AT FULL LOAD (ft-lb)	680
OUTPUT AT FULL LOAD (hp)	34.2

**2 7/8 7-8 3 Stg.**

### STANDARD RUBBER

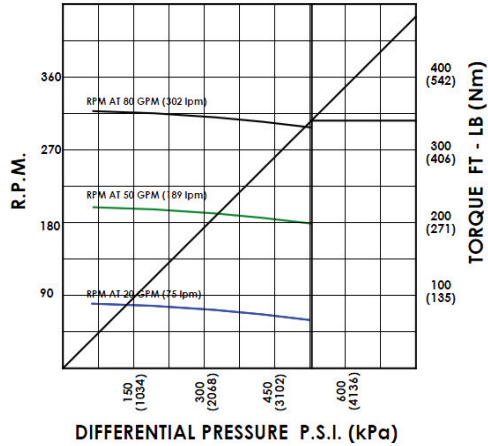

DIFFERENTIAL PRESSURE P.S.I. (kPa)

VOLUME (gpm)	20-80
SPEED (rpm)	60-320
TORQUE AT FULL LOAD (ft-lb)	340
OUTPUT AT FULL LOAD (hp)	19.3

### 2 7/8" 7 - 8 3.5 Stg

SEALED BEARING  
 BIT TO BEND FIXED 30.3"  
 BIT TO BEND ADJ. 37.3"  
 MAX W.O.B. 9,360 lb.  
 O/A LENGTH 132.9"  
 MAX. OVERPULL AND RERUN 26,700 lb.  
 ABSOLUTE OVERPULL 124,000 lb.  
 TOOL SHIPPING WEIGHT 178 lb.

HOLE SIZE 3 3/4" - 4 1/8"  
 BIT BOX CONN. 2 3/8 REG.  
 ADJUSTABLE TORQUE 2000 ft-lb  
 REV/ GAL AT FULL LOAD 3.71  
 REV/ GAL AT NO LOAD 4.00

DIFF. PRES. STANDARD 530 psi  
 DIFF. PRES. HARD 790 psi

### HARD RUBBER

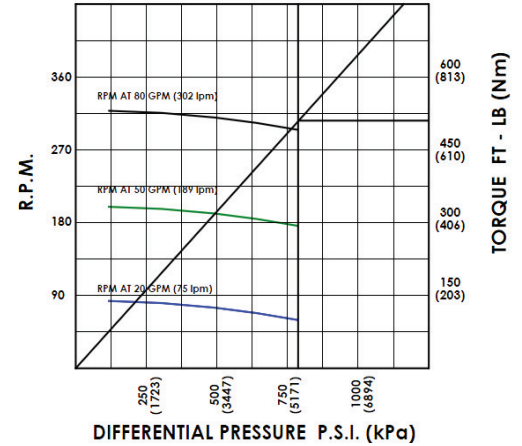

DIFFERENTIAL PRESSURE P.S.I. (kPa)

VOLUME (gpm)	20-80
SPEED (rpm)	60-320
TORQUE AT FULL LOAD (ft-lb)	510
OUTPUT AT FULL LOAD (hp)	28.9

## 2 7/8" 7 - 8 3.6 Stg EW

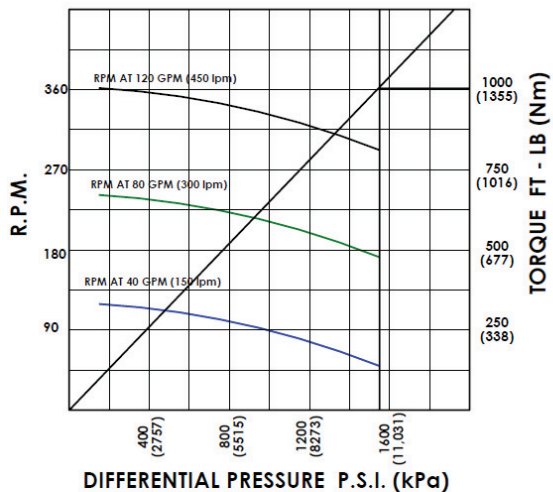

DIFFERENTIAL PRESSURE P.S.I. (kPa)

VOLUME (gpm)	40-120
SPEED (rpm)	50-360
TORQUE AT FULL LOAD (ft-lb)	1550
OUTPUT AT FULL LOAD (hp)	57

SEALED BEARING  
 BIT TO BEND FIXED 30.3"  
 BIT TO BEND ADJ. 37.3"  
 MAX W.O.B. 9,360 lb.  
 O/A LENGTH 127.8"  
 MAX. OVERPULL AND RERUN 26,700 lb.  
 ABSOLUTE OVERPULL 124,000 lb.  
 TOOL SHIPPING WEIGHT 169 lb.

HOLE SIZE 3 3/4" - 4 1/8"  
 BIT BOX CONN. 2 3/8 REG.  
 ADJUSTABLE TORQUE 2000 ft-lb  
 REV/ GAL AT FULL LOAD 2.44  
 REV/ GAL AT NO LOAD 3.00

DIFF. PRES. 1550 psi

2 7/8" 7-8 3.6 Stg.

**STANDARD RUBBER**

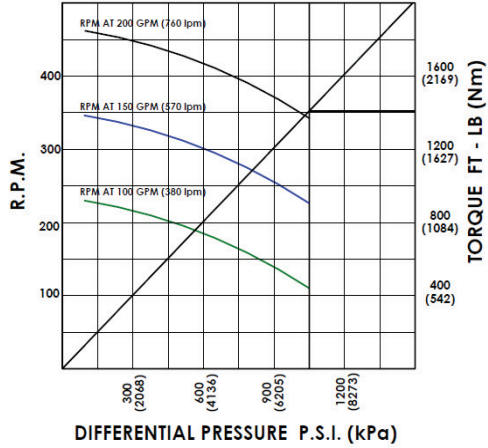

VOLUME (gpm)	100-200
SPEED (rpm)	110-460
TORQUE AT FULL LOAD (ft-lb)	1410
OUTPUT AT FULL LOAD (hp)	93.1

**3 1/8" 5 - 6 3.5 Stg**

**SEALED BEARING**  
 BIT TO BEND FIXED 32.1"  
 BIT TO BEND ADJ. 39.4"  
 MAX W.O.B. 23,650 lb.  
 O/A LENGTH 194.8 lb.  
 MAX. OVERPULL AND RERUN 40,000 lb.  
 ABSOLUTE OVERPULL 90,000 lb.  
 TOOL SHIPPING WEIGHT 316.5 lb.

**HOLE SIZE** 3 7/8" - 4 1/2"  
**BIT BOX CONN.** 2 3/8 REG.  
**ADJUSTABLE TORQUE** 2700 ft-lb  
**REV/ GAL AT FULL LOAD** 1.73  
**REV/ GAL AT NO LOAD** 2.30

**DIFF. PRES. STANDARD** 1050 psi  
**DIFF. PRES. HARD** 1230 psi

**HARD RUBBER**

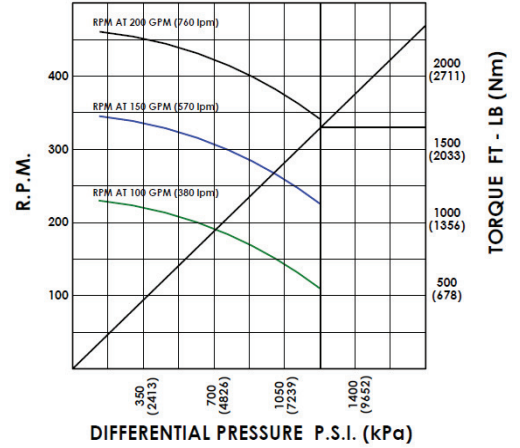

VOLUME (gpm)	100-200
SPEED (rpm)	110-460
TORQUE AT FULL LOAD (ft-lb)	1650
OUTPUT AT FULL LOAD (hp)	109.8

**3 1/8 5-6 3.5 Stg.**



**STANDARD RUBBER**

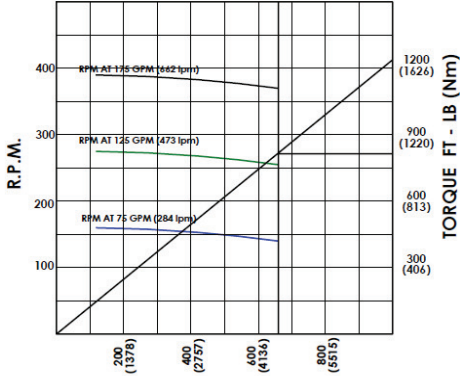

DIFFERENTIAL PRESSURE P.S.I. (kPa)

VOLUME (gpm)	75-175
SPEED (rpm)	140-390
TORQUE AT FULL LOAD (ft-lb)	660
OUTPUT AT FULL LOAD (hp)	57.5

**3 1/8" 5 - 6 5.0 Stg**

SEALED BEARING  
 BIT TO BEND FIXED 32.1"  
 BIT TO BEND ADJ. 39.4"  
 MAX W.O.B. 23 450 lb.  
 O/A LENGTH 208.3 lb.  
 MAX. OVERPULL AND RERUN 60,000 lb.  
 ABSOLUTE OVERPULL 90,000 lb.  
 TOOL SHIPPING WEIGHT 296.2 lb.

HOLE SIZE 3 7/8" - 4 1/2"  
 BIT BOX CONN. 2 3/8 REG.  
 ADJUSTABLE TORQUE 2700 ft-lb  
 REV/ GAL AT FULL LOAD 2.11  
 REV/ GAL AT NO LOAD 2.22

DIFF. PRES. STANDARD 660 psi  
 DIFF. PRES. HARD 828 psi

**HARD RUBBER**

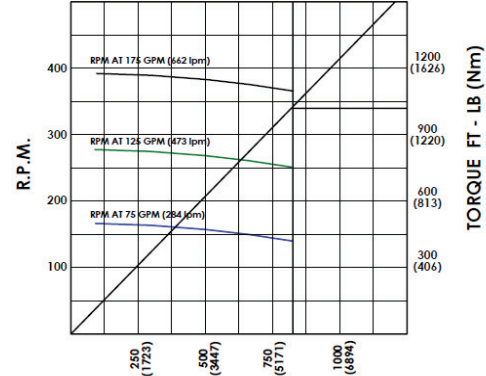

DIFFERENTIAL PRESSURE P.S.I. (kPa)

VOLUME (gpm)	75-175
SPEED (rpm)	140-390
TORQUE AT FULL LOAD (ft-lb)	1020
OUTPUT AT FULL LOAD (hp)	72

### STANDARD RUBBER

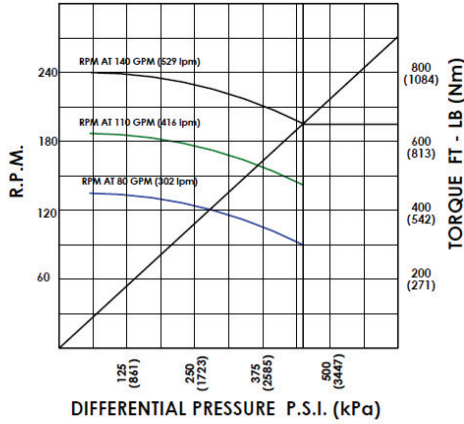

VOLUME (gpm)	80-140
SPEED (rpm)	80-240
TORQUE AT FULL LOAD (ft-lb)	650
OUTPUT AT FULL LOAD (hp)	24.1

### 3 1/8" 7 - 8 3.0 Stg

**SEALED BEARING**  
 BIT TO BEND FIXED 32.1"  
 BIT TO BEND ADJ. 39.4"  
 MAX W.O.B. 23,650 lb.  
 O/A LENGTH 181.3"  
 MAX. OVERPULL AND RERUN 60,000 lb.  
 ABSOLUTE OVERPULL 90,000 lb.  
 TOOL SHIPPING WEIGHT 301.3 lb.

**HOLE SIZE** 3 7/8" - 4 1/2"  
**BIT BOX CONN.** 2 3/8 REG.  
**ADJUSTABLE TORQUE** 2700 ft-lb  
**REV/ GAL AT FULL LOAD** 1.39  
**REV/ GAL AT NO LOAD** 1.71

**DIFF. PRES. STANDARD** 450 psi  
**DIFF. PRES. HARD** 980 psi

### HARD RUBBER

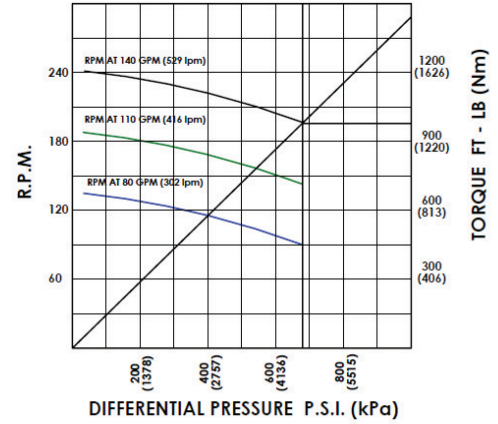

VOLUME (gpm)	80-140
SPEED (rpm)	80-240
TORQUE AT FULL LOAD (ft-lb)	980
OUTPUT AT FULL LOAD (hp)	36.4

3 1/8 7-8 3 Stg.

### STANDARD RUBBER

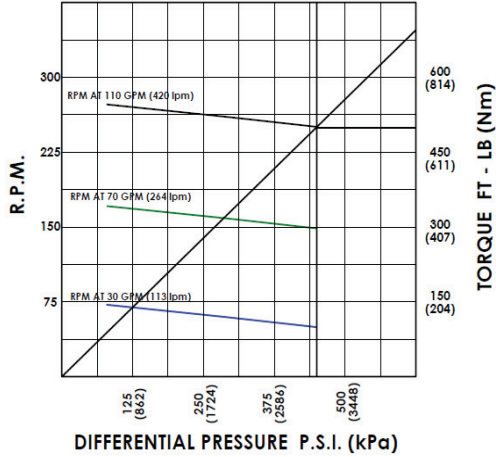

DIFFERENTIAL PRESSURE P.S.I. (kPa)

VOLUME (gpm)	30-110
SPEED (rpm)	50-270
TORQUE AT FULL LOAD (ft-lb)	500
OUTPUT AT FULL LOAD (hp)	23.9

### 3 1/2" 5 - 6 3 Stg

**MUD LUBE**  
 BIT TO BEND FIXED 32"  
 BIT TO BEND ADJ. 42"  
 MAX W.O.B. 23,000 lb.  
 O/A LENGTH 148.4"  
 MAX. OVERPULL AND RERUN 75,000 lb.  
 ABSOLUTE OVERPULL 120,000 lb.  
 TOOL SHIPPING WEIGHT 300 lb.

**SEALED BEARING**  
 BIT TO BEND FIXED 37.6"  
 BIT TO BEND ADJ. 45"  
 MAX W.O.B. 23,150 lb.  
 O/A LENGTH 230.8"  
 MAX. OVERPULL AND RERUN 68,450 lb.  
 ABSOLUTE OVERPULL 275,000 lb.  
 TOOL SHIPPING WEIGHT 501.6 lb.

**HOLE SIZE**  
 BIT BOX CONN. 2 7/8 REG./ 2 3/8 REG  
 ADJUSTABLE TORQUE 3200 ft-lb  
 REV/ GAL AT FULL LOAD 2.28  
 REV/ GAL AT NO LOAD 2.46

DIFF. PRES. STANDARD 450 psi  
 DIFF. PRES. HARD 680 psi

### HARD RUBBER

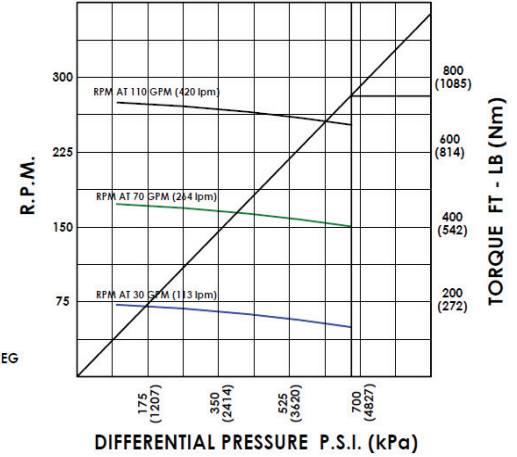

DIFFERENTIAL PRESSURE P.S.I. (kPa)

VOLUME (gpm)	30-110
SPEED (rpm)	50-270
TORQUE AT FULL LOAD (ft-lb)	750
OUTPUT AT FULL LOAD (hp)	35.8

**STANDARD RUBBER**

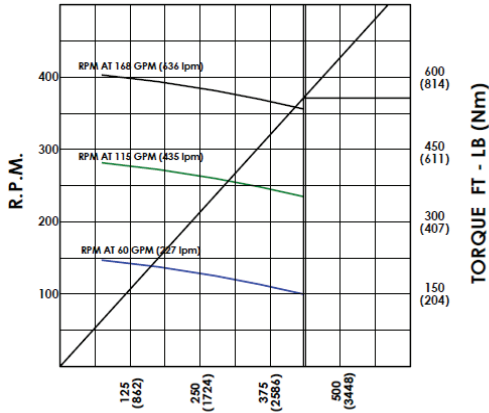

**DIFFERENTIAL PRESSURE P.S.I. (kPa)**

VOLUME (gpm)	60-168
SPEED (rpm)	100-412
TORQUE AT FULL LOAD (ft-lb)	557
OUTPUT AT FULL LOAD (hp)	38

**3 1/2" 5 - 6 3 Stg**

**MUD LUBE**  
 BIT TO BEND FIXED 32"  
 BIT TO BEND ADJ. 42"  
 MAX W.O.B. 23,000 lb.  
 O/A LENGTH 148.4"  
 MAX. OVERPULL AND RERUN 95,000 lb.  
 ABSOLUTE OVERPULL 120,000 lb.  
 TOOL SHIPPING WEIGHT 294 lb.

**SEALED BEARING**  
 BIT TO BEND FIXED 37.6"  
 BIT TO BEND ADJ. 45"  
 MAX W.O.B. 23,150 lb.  
 O/A LENGTH 230.8"  
 MAX. OVERPULL AND RERUN 48,450 lb.  
 ABSOLUTE OVERPULL 275,000 lb.  
 TOOL SHIPPING WEIGHT 501.6 lb.

**HOLE SIZE**  
 BIT BOX CONN. 2 7/8 REG. / 2 3/8 REG  
 ADJUSTABLE TORQUE 3200 ft-lb  
 REV/ GAL AT FULL LOAD 2.12  
 REV/ GAL AT NO LOAD 2.46

**DIFF. PRES. STANDARD** 435 psi  
**DIFF. PRES. HARD** 453 psi

**HARD RUBBER**

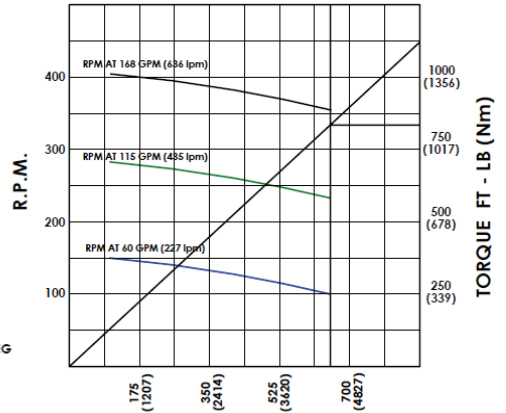

**DIFFERENTIAL PRESSURE P.S.I. (kPa)**

VOLUME (gpm)	60-168
SPEED (rpm)	100-412
TORQUE AT FULL LOAD (ft-lb)	836
OUTPUT AT FULL LOAD (hp)	56.9

### STANDARD RUBBER

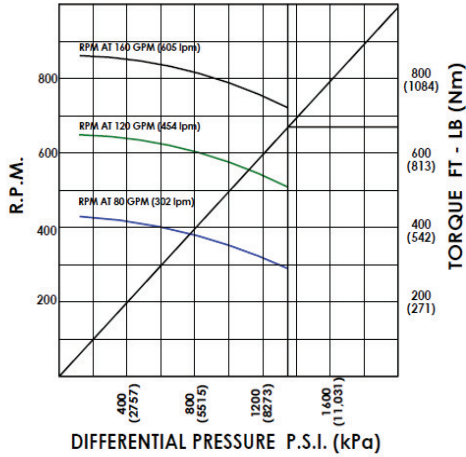

DIFFERENTIAL PRESSURE P.S.I. (kPa)

VOLUME (gpm)	80-160
SPEED (rpm)	290-860
TORQUE AT FULL LOAD (ft-lb)	670
OUTPUT AT FULL LOAD (hp)	92.2

### 3 3/4" 3 - 4 9 Stg

**MUD LUBE**  
 BIT TO BEND FIXED 35.4"  
 BIT TO BEND ADJ. 43"  
 MAX W.O.B. 26,450 lb.  
 O/A LENGTH 222.7"  
 MAX. OVERPULL AND RERUN 103,000 lb.  
 ABSOLUTE OVERPULL 165,000 lb.  
 TOOL SHIPPING WEIGHT 475.5 lb.

**SEALED BEARING**  
 BIT TO BEND FIXED 37.4"  
 BIT TO BEND ADJ. 45"  
 MAX W.O.B. 23,150 lb.  
 O/A LENGTH 230.8"  
 MAX. OVERPULL AND RERUN 68,450 lb.  
 ABSOLUTE OVERPULL 275,000 lb.  
 TOOL SHIPPING WEIGHT 501.6 lb.

**HOLE SIZE** 4 3/4" - 5 7/8"  
 BIT BOX CONN. 2 7/8 REG.  
 ADJUSTABLE TORQUE 3500 ft-lb  
 REV/ GAL AT FULL LOAD 4.51  
 REV/ GAL AT NO LOAD 5.37

DIFF. PRES. STANDARD 1350 psi  
 DIFF. PRES. HARD 2030 psi

### HARD RUBBER

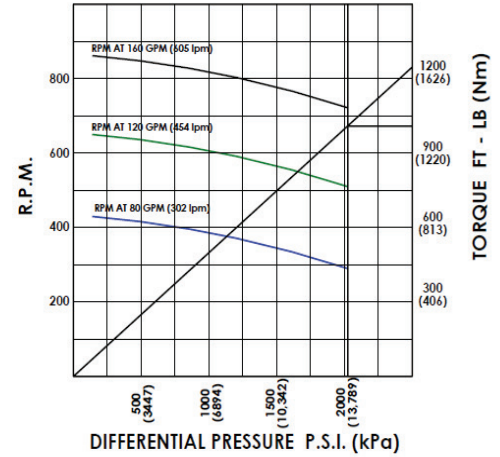

DIFFERENTIAL PRESSURE P.S.I. (kPa)

VOLUME (gpm)	80-160
SPEED (rpm)	290-860
TORQUE AT FULL LOAD (ft-lb)	1010
OUTPUT AT FULL LOAD (hp)	139

3 3/4 3-4 9 Stg.

STANDARD RUBBER

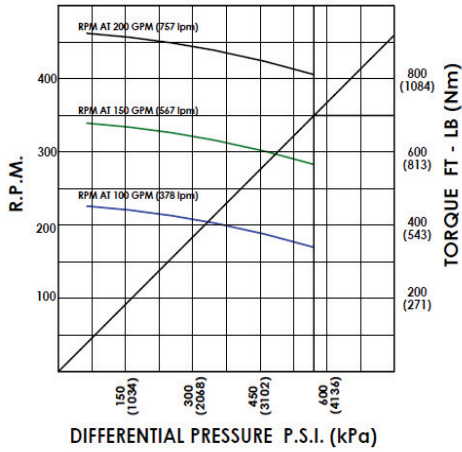

DIFFERENTIAL PRESSURE P.S.I. (kPa)

VOLUME (gpm)	100-200
SPEED (rpm)	170-460
TORQUE AT FULL LOAD (ft-lb)	700
OUTPUT AT FULL LOAD (hp)	54.2

3 3/4" 5 - 6 3.8 Stg

MUD LUBE  
 BIT TO BEND FIXED 35.4"  
 BIT TO BEND ADJ. 43"  
 MAX W.O.B. 26,450 lb.  
 O/A LENGTH 154.2"  
 MAX. OVERPULL AND RERUN 103,000 lb.  
 ABSOLUTE OVERPULL 165,000 lb.  
 TOOL SHIPPING WEIGHT 339.5 lb.

SEALED BEARING  
 BIT TO BEND FIXED 37.6"  
 BIT TO BEND ADJ. 45"  
 MAX W.O.B. 23,150 lb.  
 O/A LENGTH 142.3"  
 MAX. OVERPULL AND RERUN 68,450 lb.  
 ABSOLUTE OVERPULL 275,000 lb.  
 TOOL SHIPPING WEIGHT 365.6 lb.

HOLE SIZE 4 3/4" - 5 7/8"  
 BIT BOX CONN. 2 7/8 REG.  
 ADJUSTABLE TORQUE 3500 ft-lb  
 REV/ GAL AT FULL LOAD 2.03  
 REV/ GAL AT NO LOAD 2.30

DIFF. PRES. 570 psi

3 3/4 5-6 3.8 Stg.

### STANDARD RUBBER

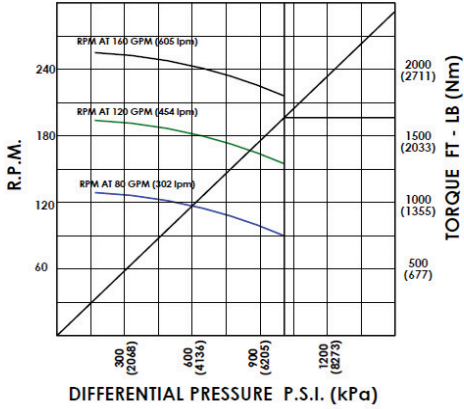

DIFFERENTIAL PRESSURE P.S.I. (kPa)

VOLUME (gpm)	80-160
SPEED (rpm)	90-260
TORQUE AT FULL LOAD (ft-lb)	1640
OUTPUT AT FULL LOAD (hp)	67.5

### 3 3/4" 7 - 8 6.7 Stg

**MUD LUBE**  
 BIT TO BEND FIXED 35.4"  
 BIT TO BEND ADJ. 43"  
 MAX. W.O.B. 26,450 lb.  
 O/A LENGTH 253.7'  
 MAX. OVERPULL AND RERUN 103,000 lb.  
 ABSOLUTE OVERPULL 165,000 lb.  
 TOOL SHIPPING WEIGHT 553.5 lb.

**SEALED BEARING**  
 BIT TO BEND FIXED 37.6"  
 BIT TO BEND ADJ. 45"  
 MAX. W.O.B. 23,150 lb.  
 O/A LENGTH 241.8'  
 MAX. OVERPULL AND RERUN 68,450 lb.  
 ABSOLUTE OVERPULL 275,000 lb.  
 TOOL SHIPPING WEIGHT 600 lb.

**HOLE SIZE** 4 3/4" - 5 7/8"  
 BIT BOX CONN. 2 7/8 REG.  
 ADJUSTABLE TORQUE 3500 ft-lb  
 REV/ GAL AT FULL LOAD 1.35  
 REV/ GAL AT NO LOAD 1.62

DIFF. PRES. STANDARD 1010 psi  
 DIFF. PRES. HARD 1510 psi

### HARD RUBBER

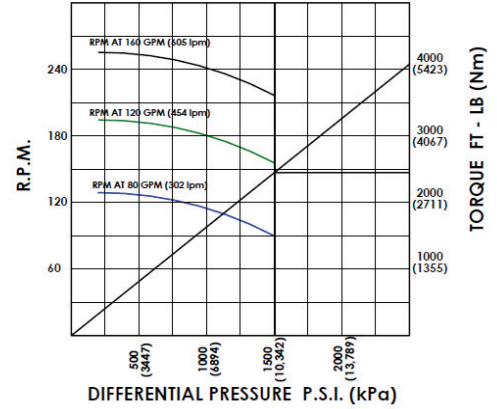

DIFFERENTIAL PRESSURE P.S.I. (kPa)

VOLUME (gpm)	80-160
SPEED (rpm)	90-260
TORQUE AT FULL LOAD (ft-lb)	2460
OUTPUT AT FULL LOAD (hp)	101.3

3 3/4 7-8 6.7 Stg.

# 4 3/4" 4 - 5 3.6 Stg EW

**MUD LUBE**  
 BIT TO BEND FIXED 49.3"  
 BIT TO BEND ADJ. 59.5"  
 MAX W.O.B. 49,000 lb.  
 O/A LENGTH 231.5"  
 MAX. OVERPULL AND RERUN 49,000 lb.  
 ABSOLUTE OVERPULL 350,000 lb.  
 TOOL SHIPPING WEIGHT 934.6 lb.

**SEALED BEARING**  
 BIT TO BEND FIXED 48.8"  
 BIT TO BEND ADJ. 59.8"  
 MAX W.O.B. 77,000 lb.  
 O/A LENGTH 231"  
 MAX. OVERPULL AND RERUN 159,000 lb.  
 ABSOLUTE OVERPULL 325,000 lb.  
 TOOL SHIPPING WEIGHT 935 lb.

**HOLE SIZE** 6" - 6 3/4"  
**BIT BOX CONN.** 3 1/2 REG.  
**ADJUSTABLE TORQUE** 10,000 ft-lb  
**REV/ GAL AT FULL LOAD** 0.76  
**REV/ GAL AT NO LOAD** 1.00

**DIFF. PRES.** 1525 psi

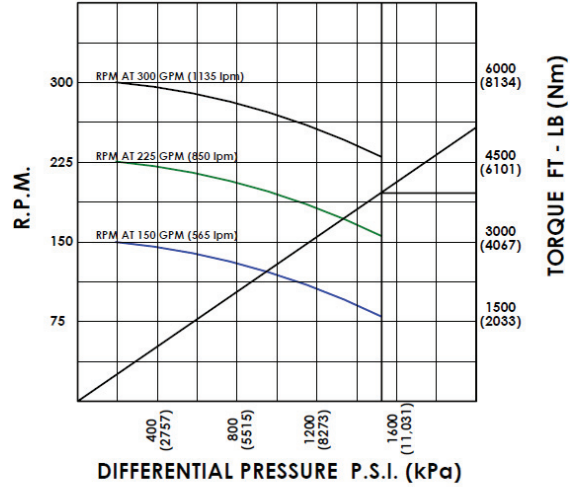

<b>VOLUME (gpm)</b>	<b>150-300</b>
<b>SPEED (rpm)</b>	<b>80-300</b>
<b>TORQUE AT FULL LOAD (ft-lb)</b>	<b>3925</b>
<b>OUTPUT AT FULL LOAD (hp)</b>	<b>171.1</b>

**4 3/4" 4-5 3.6 Stg.**



# 4 3/4" 4 - 5 5.4 Stg EW

**MUD LUBE**  
 BIT TO BEND FIXED 49.3"  
 BIT TO BEND ADJ. 59.5"  
 MAX W.O.B. 49,000 lb.  
 O/A LENGTH 303.5"  
 MAX. OVERPULL AND RERUN 49,000 lb.  
 ABSOLUTE OVERPULL 350,000 lb.  
 TOOL SHIPPING WEIGHT 1179.6 lb.

**SEALED BEARING**  
 BIT TO BEND FIXED 48.8"  
 BIT TO BEND ADJ. 59.8"  
 MAX W.O.B. 77,000 lb.  
 O/A LENGTH 303"  
 MAX. OVERPULL AND RERUN 159,000 lb.  
 ABSOLUTE OVERPULL 325,000 lb.  
 TOOL SHIPPING WEIGHT 1180 lb.

**HOLE SIZE** 6" - 6 3/4"  
 BIT BOX CONN. 3 1/2 REG.  
 ADJUSTABLE TORQUE 10,000 ft-lb  
 REV/ GAL AT FULL LOAD 0.73  
 REV/ GAL AT NO LOAD 1.00

DIFF. PRES. 1775 psi

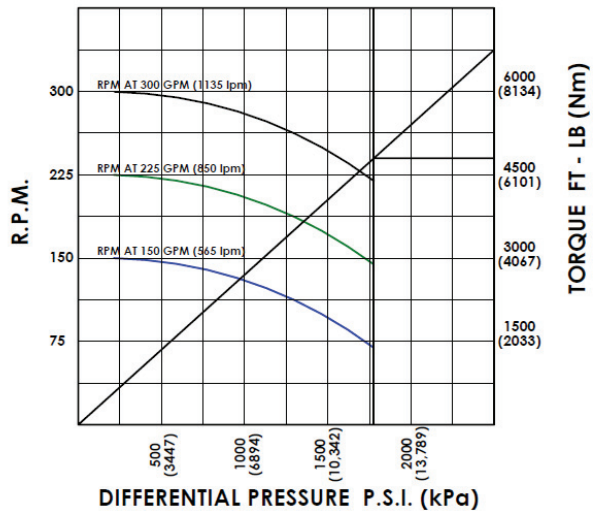

VOLUME (gpm)	150-300
SPEED (rpm)	70-300
TORQUE AT FULL LOAD (ft-lb)	4800
OUTPUT AT FULL LOAD (hp)	200.1

4 3/4" 4-5 5.4 Stg.

### STANDARD RUBBER

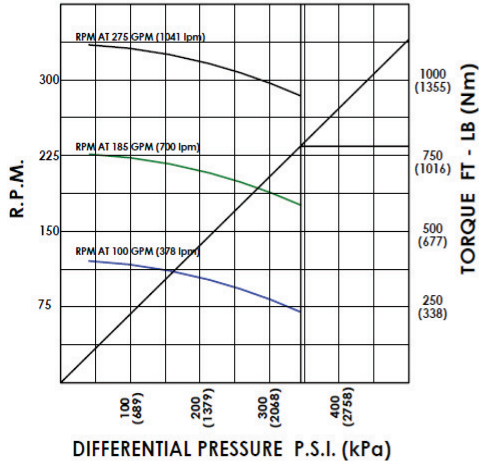

DIFFERENTIAL PRESSURE P.S.I. (kPa)

VOLUME (gpm)	100-275
SPEED (rpm)	70-334
TORQUE AT FULL LOAD (ft-lb)	784
OUTPUT AT FULL LOAD (hp)	42.5

### 4 3/4" 5 - 6 3.0 Stg

**MUD LUBE**  
 BIT TO BEND FIXED 49.3"  
 BIT TO BEND ADJ. 59.5"  
 MAX W.O.B. 49,000 lb.  
 O/A LENGTH 194.9"  
 MAX. OVERPULL AND RERUN 49,000 lb.  
 ABSOLUTE OVERPULL 350,000 lb.  
 TOOL SHIPPING WEIGHT 718 lb.

**SEALED BEARING**  
 BIT TO BEND FIXED 48.8"  
 BIT TO BEND ADJ. 59.8"  
 MAX W.O.B. 77,000 lb.  
 O/A LENGTH 191"  
 MAX. OVERPULL AND RERUN 159,000 lb.  
 ABSOLUTE OVERPULL 325,000 lb.  
 TOOL SHIPPING WEIGHT 747.4 lb.

**HOLE SIZE** 4" - 4 3/4"  
 BIT BOX CONN. 3 1/2 REG.  
 ADJUSTABLE TORQUE 10,000 ft-lb  
 REV/ GAL AT FULL LOAD 1.03  
 REV/ GAL AT NO LOAD 1.21

DIFF. PRES. STANDARD 346 psi  
 DIFF. PRES. HARD 432 psi

### HARD RUBBER

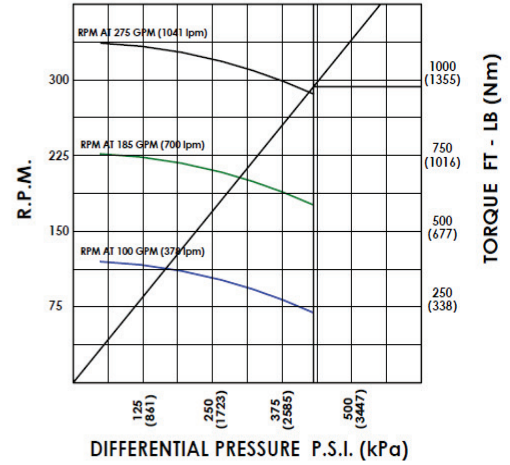

DIFFERENTIAL PRESSURE P.S.I. (kPa)

VOLUME (gpm)	100-275
SPEED (rpm)	70-334
TORQUE AT FULL LOAD (ft-lb)	980
OUTPUT AT FULL LOAD (hp)	53.1

4 3/4 5-6 3 Stg.

### STANDARD RUBBER

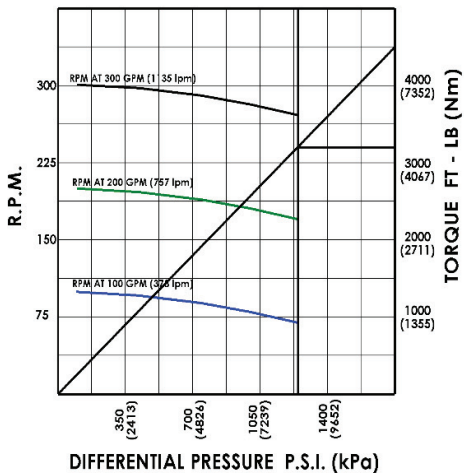

DIFFERENTIAL PRESSURE P.S.I. (kPa)

VOLUME (gpm)	100-300
SPEED (rpm)	70-300
TORQUE AT FULL LOAD (ft-lb)	3210
OUTPUT AT FULL LOAD (hp)	165.3

### 4 3/4" 5 - 6 8.3 Stg

**MUD LUBE**  
 BIT TO BEND FIXED 49.3"  
 BIT TO BEND ADJ. 59.5"  
 MAX W.O.B. 49,000 lb.  
 O/A LENGTH 346.1'  
 MAX. OVERPULL AND RERUN 49,000 lb.  
 ABSOLUTE OVERPULL 350,000 lb.  
 TOOL SHIPPING WEIGHT 1259.6 lb.

**SEALED BEARING**  
 BIT TO BEND FIXED 48.8"  
 BIT TO BEND ADJ. 59.8"  
 MAX W.O.B. 77,000 lb.  
 O/A LENGTH 345.6'  
 MAX. OVERPULL AND RERUN 159,000 lb.  
 ABSOLUTE OVERPULL 325,000 lb.  
 TOOL SHIPPING WEIGHT 1260 lb.

**HOLE SIZE** 6" - 6 3/4"  
**BIT BOX CONN.** 3 1/2 REG.  
**ADJUSTABLE TORQUE** 10,000 ft-lb  
**REV/ GAL AT FULL LOAD** 0.90  
**REV/ GAL AT NO LOAD** 1.00

**DIFF. PRES. STANDARD** 1250 psi  
**DIFF. PRES. HARD** 1870 psi

### HARD RUBBER

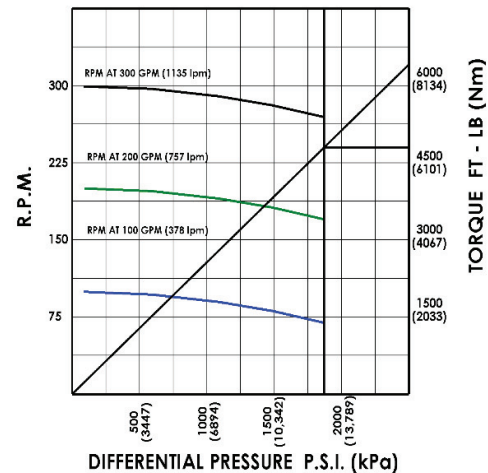

DIFFERENTIAL PRESSURE P.S.I. (kPa)

VOLUME (gpm)	100-300
SPEED (rpm)	70-300
TORQUE AT FULL LOAD (ft-lb)	4810
OUTPUT AT FULL LOAD (hp)	247.6

4 3/4" 5-6 8.3 Stg.

# 4 3/4" 6 - 7 2.5 Stg EW

**MUD LUBE**  
 BIT TO BEND FIXED 49.3"  
 BIT TO BEND ADJ. 59.5"  
 MAX. W.O.B. 49,000 lb.  
 O/A LENGTH 285.5"  
 MAX. OVERPULL AND RERUN 49,000 lb.  
 ABSOLUTE OVERPULL 350,000 lb.  
 TOOL SHIPPING WEIGHT 1049.6 lb.

**SEALED BEARING**  
 BIT TO BEND FIXED 48.8"  
 BIT TO BEND ADJ. 59.8"  
 MAX. W.O.B. 77,000 lb.  
 O/A LENGTH 285"  
 MAX. OVERPULL AND RERUN 159,000 lb.  
 ABSOLUTE OVERPULL 325,000 lb.  
 TOOL SHIPPING WEIGHT 1050 lb.

**HOLE SIZE** 6" - 6 3/4"  
 BIT BOX CONN. 3 1/2 REG.  
 ADJUSTABLE TORQUE 10,000 ft-lb  
 REV/ GAL AT FULL LOAD 0.35  
 REV/ GAL AT NO LOAD 0.44

DIFF. PRES. 1180 psi

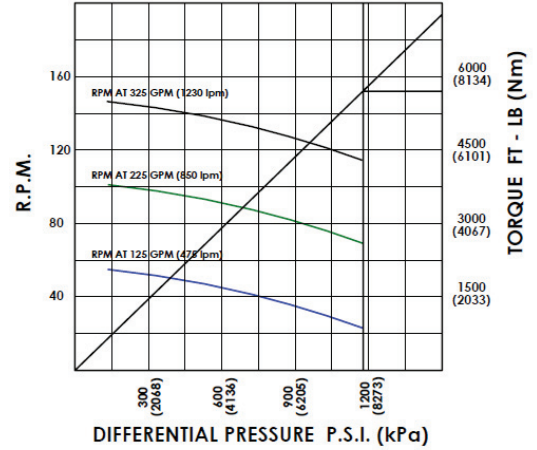

VOLUME (gpm)	125-325
SPEED (rpm)	23-145
TORQUE AT FULL LOAD (ft-lb)	5700
OUTPUT AT FULL LOAD (hp)	123.9

**4 3/4" 6-7 2.5 Stg.**

**STANDARD RUBBER**

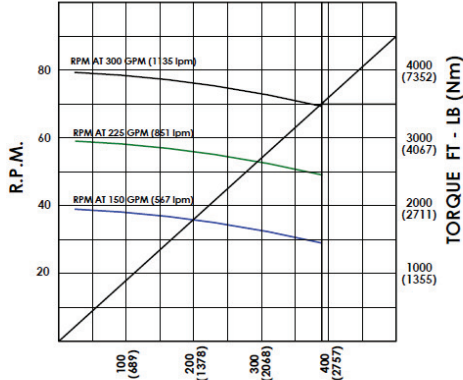

**DIFFERENTIAL PRESSURE P.S.I. (kPa)**

VOLUME (gpm)	150-300
SPEED (rpm)	29-79
TORQUE AT FULL LOAD (ft-lb)	3500
OUTPUT AT FULL LOAD (hp)	46

**4 3/4" 7 - 8 2.6 Stg**

**MUD LUBE**  
 BIT TO BEND FIXED 49.3"  
 BIT TO BEND ADJ. 59.5"  
 MAX W.O.B. 49,000 lb.  
 O/A LENGTH 332.8"  
 MAX. OVERPULL AND RERUN 49,000 lb.  
 ABSOLUTE OVERPULL 350,000 lb.  
 TOOL SHIPPING WEIGHT 1198.6 lb.

**SEALED BEARING**  
 BIT TO BEND FIXED 48.8"  
 BIT TO BEND ADJ. 59.8"  
 MAX W.O.B. 77,000 lb.  
 O/A LENGTH 332.8"  
 MAX. OVERPULL AND RERUN 159,000 lb.  
 ABSOLUTE OVERPULL 325,000 lb.  
 TOOL SHIPPING WEIGHT 1199 lb.

**HOLE SIZE** 6" - 6 3/4"  
 BIT BOX CONN. 3 1/2 REG.  
 ADJUSTABLE TORQUE 10,000 ft-lb  
 REV/ GAL AT FULL LOAD 0.23  
 REV/ GAL AT NO LOAD 0.26

DIFF. PRES. STANDARD 390 psi  
 DIFF. PRES. HARD 590 psi

**HARD RUBBER**

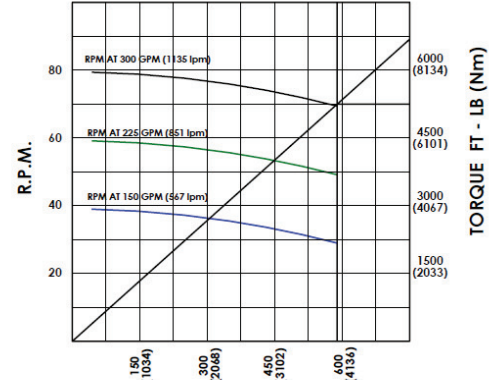

**DIFFERENTIAL PRESSURE P.S.I. (kPa)**

VOLUME (gpm)	150-300
SPEED (rpm)	29-79
TORQUE AT FULL LOAD (ft-lb)	5250
OUTPUT AT FULL LOAD (hp)	69

**4 3/4" 7-8 2.6 Stg.**

### STANDARD RUBBER

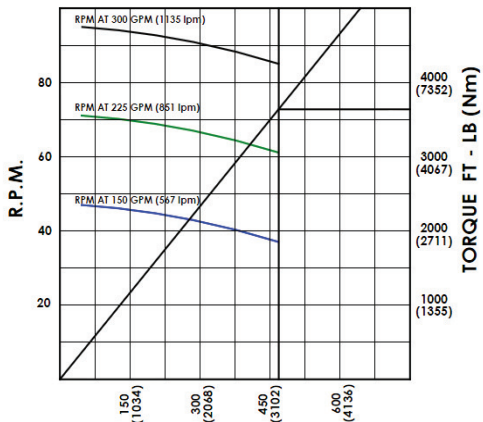

DIFFERENTIAL PRESSURE P.S.I. (kPa)

VOLUME (gpm)	150-300
SPEED (rpm)	37-95
TORQUE AT FULL LOAD (ft-lb)	3640
OUTPUT AT FULL LOAD (hp)	59

### 4 3/4" 7 - 8 3.1 Stg

MUD LUBE  
 BIT TO BEND FIXED 49.3"  
 BIT TO BEND ADJ. 59.5"  
 MAX W.O.B. 49,000 lb.  
 O/A LENGTH 341.5"  
 MAX. OVERPULL AND RERUN 49,000 lb.  
 ABSOLUTE OVERPULL 350,000 lb.  
 TOOL SHIPPING WEIGHT 1337.6 lb.

SEALED BEARING  
 BIT TO BEND FIXED 48.8"  
 BIT TO BEND ADJ. 59.8"  
 MAX W.O.B. 77,000 lb.  
 O/A LENGTH 341"  
 MAX. OVERPULL AND RERUN 159,000 lb.  
 ABSOLUTE OVERPULL 325,000 lb.  
 TOOL SHIPPING WEIGHT 1338 lb.

HOLE SIZE 6" - 6 3/4"  
 BIT BOX CONN. 3 1/2 REG.  
 ADJUSTABLE TORQUE 10,000 ft-lb  
 REV/ GAL AT FULL LOAD 0.28  
 REV/ GAL AT NO LOAD 0.31

DIFF. PRES. STANDARD 470 psi  
 DIFF. PRES. HARD 700 psi

### HARD RUBBER

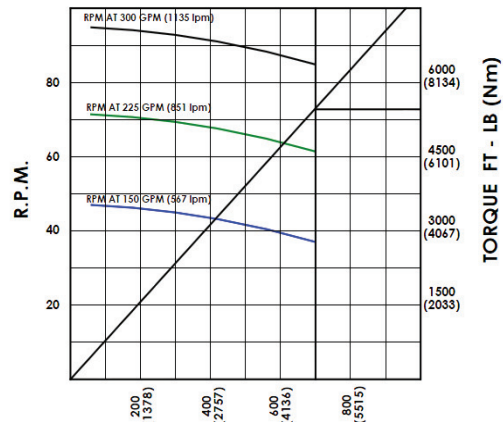

DIFFERENTIAL PRESSURE P.S.I. (kPa)

VOLUME (gpm)	150-300
SPEED (rpm)	37-95
TORQUE AT FULL LOAD (ft-lb)	5460
OUTPUT AT FULL LOAD (hp)	88.5

4 3/4" 7-8 3.1 Stg.

**STANDARD RUBBER**

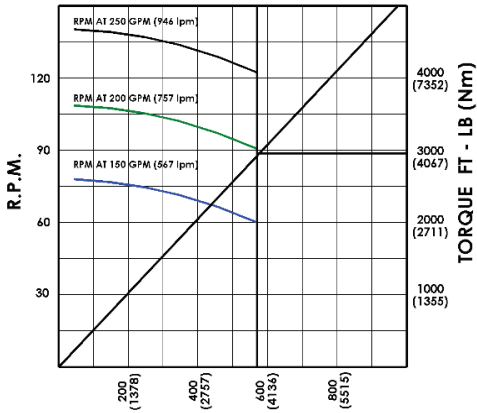

**DIFFERENTIAL PRESSURE P.S.I. (kPa)**

VOLUME (gpm)	150-250
SPEED (rpm)	60-140
TORQUE AT FULL LOAD (ft-lb)	2760
OUTPUT AT FULL LOAD (hp)	68.8

**4 3/4" 7 - 8 3.8 Stg**

**MUD LUBE**  
 BIT TO BEND FIXED 49.3"  
 BIT TO BEND ADJ. 59.5"  
 MAX W.O.B. 49,000 lb.  
 O/A LENGTH 290.5"  
 MAX. OVERPULL AND RERUN 49,000 lb.  
 ABSOLUTE OVERPULL 350,000 lb.  
 TOOL SHIPPING WEIGHT 1118.6 lb.

**SEALED BEARING**  
 BIT TO BEND FIXED 48.8"  
 BIT TO BEND ADJ. 59.8"  
 MAX W.O.B. 77,000 lb.  
 O/A LENGTH 290"  
 MAX. OVERPULL AND RERUN 159,000 lb.  
 ABSOLUTE OVERPULL 325,000 lb.  
 TOOL SHIPPING WEIGHT 1119 lb.

**HOLE SIZE** 6" - 6 3/4"  
**BIT BOX CONN.** 3 1/2 REG.  
**ADJUSTABLE TORQUE** 10,000 ft-lb  
**REV/ GAL AT FULL LOAD** 0.48  
**REV/ GAL AT NO LOAD** 0.56

**DIFF. PRES. STANDARD** 570 psi  
**DIFF. PRES. HARD** 860 psi

**HARD RUBBER**

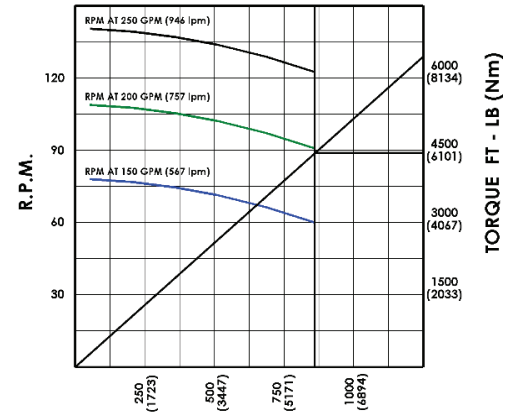

**DIFFERENTIAL PRESSURE P.S.I. (kPa)**

VOLUME (gpm)	150-250
SPEED (rpm)	60-140
TORQUE AT FULL LOAD (ft-lb)	4450
OUTPUT AT FULL LOAD (hp)	103.5

**4 3/4" 7-8 3.8 Stg.**

### STANDARD RUBBER

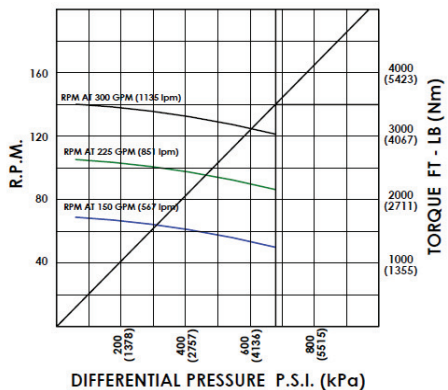

DIFFERENTIAL PRESSURE P.S.I. (kPa)

VOLUME (gpm)	150-300
SPEED (rpm)	50-140
TORQUE AT FULL LOAD (ft-lb)	3500
OUTPUT AT FULL LOAD (hp)	82.7

### 4 3/4" 7 - 8 4.5 Stg

**MUD LUBE**  
 BIT TO BEND FIXED 49.2"  
 BIT TO BEND ADJ. 59.6"  
 MAX W.O.B. 49,000 lb.  
 O/A LENGTH 332.6"  
 MAX. OVERPULL AND RERUN 49,000 lb.  
 ABSOLUTE OVERPULL 350,000 lb.  
 TOOL SHIPPING WEIGHT 1199.6 lb.

**SEALED BEARING**  
 BIT TO BEND FIXED 48.8"  
 BIT TO BEND ADJ. 59.8"  
 MAX W.O.B. 77,000 lb.  
 O/A LENGTH 332.3"  
 MAX. OVERPULL AND RERUN 159,000 lb.  
 ABSOLUTE OVERPULL 325,000 lb.  
 TOOL SHIPPING WEIGHT 1194 lb.

**HOLE SIZE** 6" - 4 3/4"  
 BIT BOX CONN. 3 1/2 REG.  
 ADJUSTABLE TORQUE 10,000 ft-lb  
 REV/GAL AT FULL LOAD 0.40  
 REV/GAL AT NO LOAD 0.46

DIFF. PRES. STANDARD 680 psi  
 DIFF. PRES. HARD 1010 psi

### HARD RUBBER

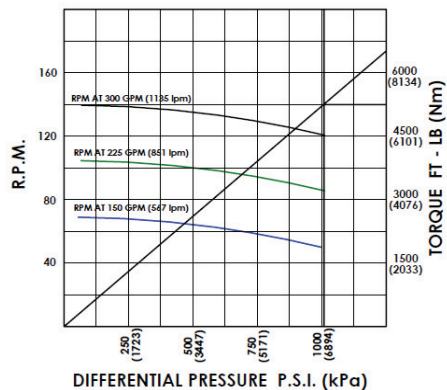

DIFFERENTIAL PRESSURE P.S.I. (kPa)

VOLUME (gpm)	150-300
SPEED (rpm)	50-140
TORQUE AT FULL LOAD (ft-lb)	5250
OUTPUT AT FULL LOAD (hp)	121.1

4 3/4 7-8 4.5 Stg.



### STANDARD RUBBER

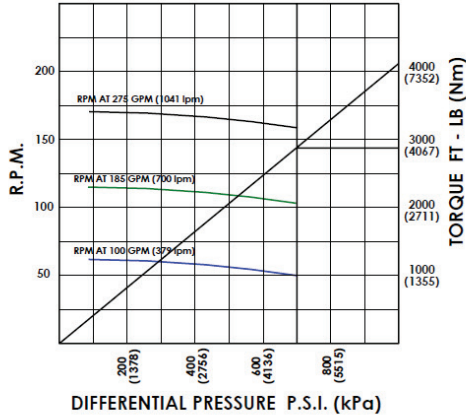

VOLUME (gpm)	100-275
SPEED (rpm)	50-171
TORQUE AT FULL LOAD (ft-lb)	2979
OUTPUT AT FULL LOAD (hp)	89.6

### 4 3/4" 7 - 8 5.0 Stg

**MUD LUBE**  
 BIT TO BEND FIXED 49.3"  
 BIT TO BEND ADJ. 59.5"  
 MAX W.O.B. 49,000 lb.  
 O/A LENGTH 297.5'  
 MAX. OVERPULL AND RERUN 49,000 lb.  
 ABSOLUTE OVERPULL 350,000 lb.  
 TOOL SHIPPING WEIGHT 1186.6 lb.

**SEALED BEARING**  
 BIT TO BEND FIXED 48.8"  
 BIT TO BEND ADJ. 59.8"  
 MAX W.O.B. 77,000 lb.  
 O/A LENGTH 297'  
 MAX. OVERPULL AND RERUN 159,000 lb.  
 ABSOLUTE OVERPULL 325,000 lb.  
 TOOL SHIPPING WEIGHT 1187 lb.

**HOLE SIZE** 6" - 6 3/4"  
**BIT BOX CONN.** 3 1/2 REG.  
**ADJUSTABLE TORQUE** 10,000 ft-lb  
**REV. GAL AT FULL LOAD** 0.57  
**REV. GAL AT NO LOAD** 0.62

**DIFF. PRES. STANDARD** 701 psi  
**DIFF. PRES. HARD** 877 psi

### HARD RUBBER

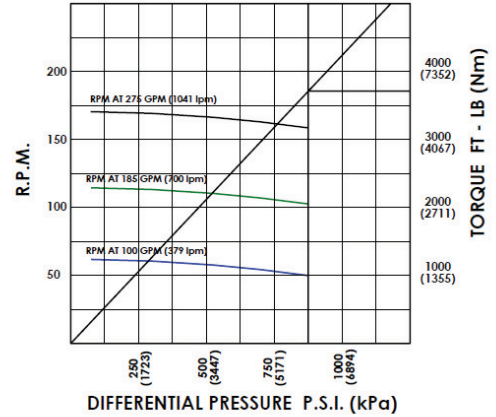

**DIFFERENTIAL PRESSURE P.S.I. (kPa)**

VOLUME (gpm)	100-275
SPEED (rpm)	50-171
TORQUE AT FULL LOAD (ft-lb)	3724
OUTPUT AT FULL LOAD (hp)	112

4 3/4 7-8 5 Stg.

**STANDARD RUBBER**

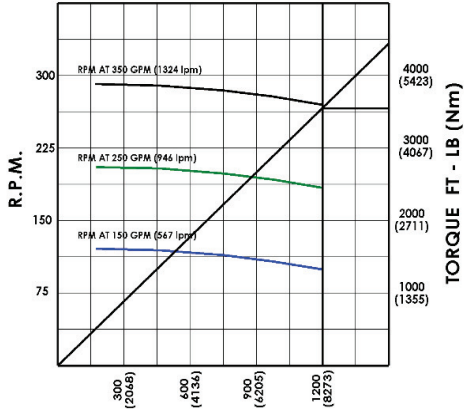

**DIFFERENTIAL PRESSURE P.S.I. (kPa)**

VOLUME (gpm)	150-350
SPEED (rpm)	100-290
TORQUE AT FULL LOAD (ft-lb)	3530
OUTPUT AT FULL LOAD (hp)	181.7

**5.00" 6 - 7 8 Stg**

**MUD LUBE**  
 BIT TO BEND FIXED 49.3"  
 BIT TO BEND ADJ. 59.6"  
 MAX W.O.B. 49,000 lb.  
 O/A LENGTH 349.5'  
 MAX. OVERPULL AND RERUN 49,000 lb.  
 ABSOLUTE OVERPULL 350,000 lb.  
 TOOL SHIPPING WEIGHT 1462 lb.

**SEALED BEARING**  
 BIT TO BEND FIXED 48.8"  
 BIT TO BEND ADJ. 59.8"  
 MAX W.O.B. 77,000 lb.  
 O/A LENGTH 349"  
 MAX OVERPULL AND RERUN 159,000 lb.  
 ABSOLUTE OVERPULL 325,000 lb.  
 TOOL SHIPPING WEIGHT 1463 lb.

**HOLE SIZE** 6" - 6 3/4"  
**BIT BOX CONN.** 3 1/2 REG.  
**ADJUSTABLE TORQUE** 10,000 ft-lb  
**REV/GAL AT FULL LOAD** 0.77  
**REV/GAL AT NO LOAD** 0.82

**DIFF. PRES. STANDARD** 1200 psi  
**DIFF. PRES. HARD** 1800 psi

**HARD RUBBER**

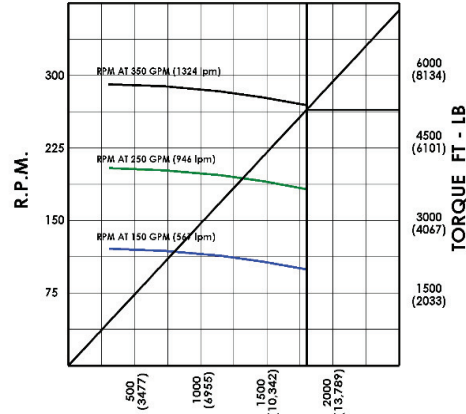

**DIFFERENTIAL PRESSURE P.S.I. (kPa)**

VOLUME (gpm)	150-350
SPEED (rpm)	100-290
TORQUE AT FULL LOAD (ft-lb)	5290
OUTPUT AT FULL LOAD (hp)	272.4

**5.00" 6-7 8 Stg.**

**STANDARD RUBBER**

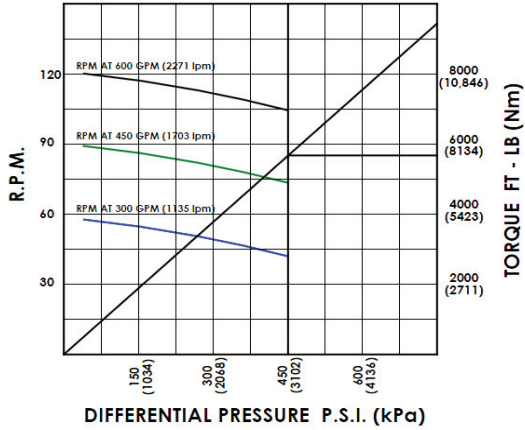

**DIFFERENTIAL PRESSURE P.S.I. (kPa)**

VOLUME (gpm)	300-600
SPEED (rpm)	42-120
TORQUE AT FULL LOAD (ft-lb)	5690
OUTPUT AT FULL LOAD (hp)	112.9

**6 1/4" 7 - 8 3 Stg**

<b>SEALED BEARING</b>	
BIT TO BEND FIXED	69.9"
BIT TO BEND ADJ	58"
MAX W.O.B	76,580 lb.
O/A LENGTH	330.6"
MAX. OVERPULL AND RERUN	219,200 lb.
ABSOLUTE OVERPULL	842,000 lb.
TOOL SHIPPING WEIGHT	2113 lb.
<b>HOLE SIZE</b>	
BIT BOX CONN.	7 7/8" - 9 7/8"
ADJUSTABLE TORQUE	4 1/2 REG.
REV/GAL AT FULL LOAD	20,000 ft-lb
REV/ GAL AT NO LAOD	0.17
	0.20
DIFF. PRES.	450 psi

**6 1/4**  
**7-8 3 Stg.**

### STANDARD RUBBER

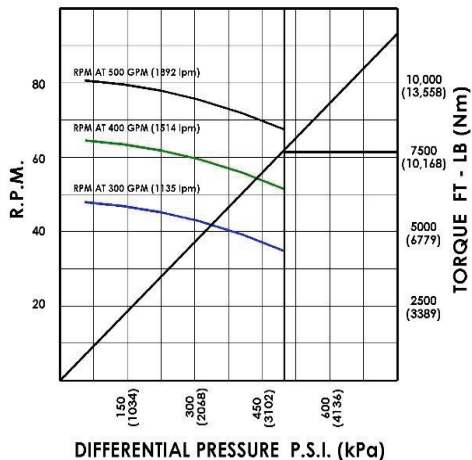

DIFFERENTIAL PRESSURE P.S.I. (kPa)

VOLUME (gpm)	300-500
SPEED (rpm)	35-80
TORQUE AT FULL LOAD (ft-lb)	7700
OUTPUT AT FULL LOAD (hp)	98.3

### 6 1/4" 7-8 3.3 Stg

**SEALED BEARING**  
 BIT TO BEND FIXED 58.2"  
 BIT TO BEND ADJ. 70.7"  
 MAX W.O.B. 76,580 lb.  
 O/A LENGTH 386.6"  
 MAX. OVERPULL AND RERUN 219,200 lb.  
 ABSOLUTE OVERPULL 842,000 lb.  
 TOOL SHIPPING WEIGHT 2402 lb.

**MUDLUBE**  
 BIT TO BEND FIXED 51.9"  
 BIT TO BEND ADJ. 63.7"  
 MAX W.O.B. 70,794 lb.  
 O/A LENGTH 379.4"  
 MAX. OVERPULL AND RERUN 295,556 lb.  
 ABSOLUTE OVERPULL 578,657 lb.  
 TOOL SHIPPING WEIGHT 2401 lb.

**HOLE SIZE** 7 7/8" - 9 7/8"  
**BIT BOX CONN.** 4 1/2 REG.  
**ADJUSTABLE TORQUE** 20,000 ft-lb  
**REV/GAL AT FULL LOAD** 0.13  
**REV/GAL AT NO LOAD** 0.16

**DIFF. PRES. STANDARD** 500 psi  
**DIFF. PRES. HARD** 740 psi

### HARD RUBBER

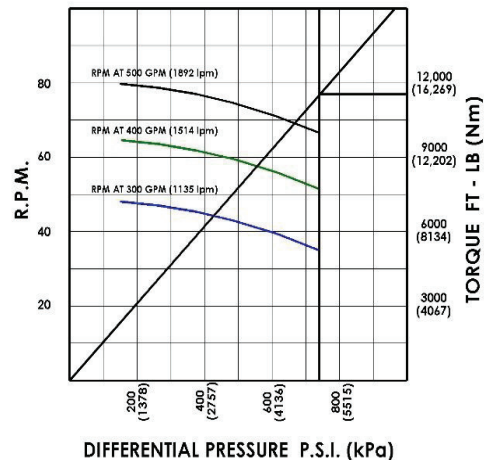

DIFFERENTIAL PRESSURE P.S.I. (kPa)

VOLUME (gpm)	300-500
SPEED (rpm)	35-80
TORQUE AT FULL LOAD (ft-lb)	11550
OUTPUT AT FULL LOAD (hp)	148

6 1/4" 7-8 3.3 Stg.

**STANDARD RUBBER**

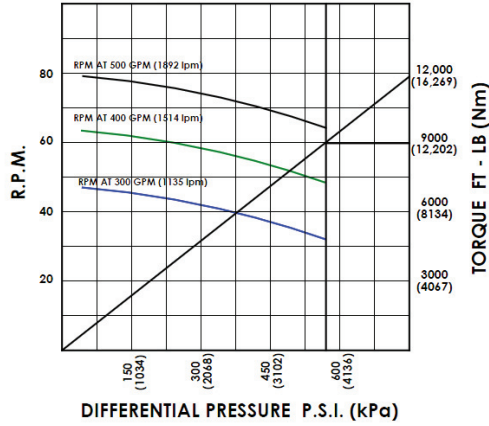

VOLUME (gpm)	300-500
SPEED (rpm)	32-79
TORQUE AT FULL LOAD (ft-lb)	8980
OUTPUT AT FULL LOAD (hp)	109.6

**6 1/4" 7 - 8 3.8 Stg**

SEALED BEARING  
 BIT TO BEND FIXED 69.9"  
 BIT TO BEND ADJ. 58"  
 MAX W.O.B 76,580 lb.  
 O/A LENGTH 426.4"  
 MAX. OVERPULL AND RERUN 219,200 lb.  
 ABSOLUTE OVERPULL 842,000 lb.  
 TOOL SHIPPING WEIGHT 2616 lb.

HOLE SIZE 7 7/8" - 9 7/8"  
 BIT BOX CONN. 4 1/2 REG.  
 ADJUSTABLE TORQUE 20,000 ft-lb  
 REV/GAL AT FULL LOAD 0.12  
 REV/ GAL AT NO LAOD 0.15

DIFF. PRES. 570 psi

**6 1/4**  
**7-8 3.8 Stg.**

### STANDARD RUBBER

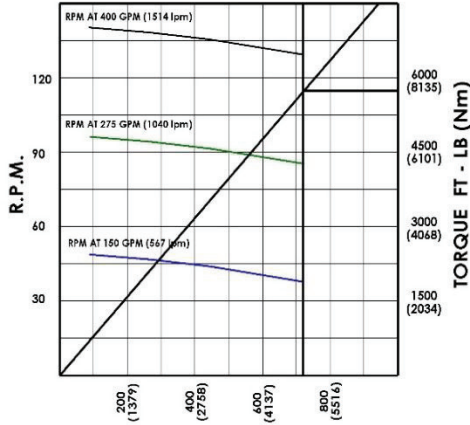

DIFFERENTIAL PRESSURE P.S.I. (kPa)

VOLUME (gpm)	150-400
SPEED (rpm)	38-140
TORQUE AT FULL LOAD (ft-lb)	5740
OUTPUT AT FULL LOAD (hp)	140.9

### 6 1/4" 7 - 8 4.8 Stg

#### SEALED BEARING

BIT TO BEND FIXED 58.2"  
 BIT TO BEND ADJ. 70.7"  
 MAX W.O.B. 76,580 lb.  
 O/A LENGTH 329.5'  
 MAX. OVERPULL AND RERUN 219,200 lb.  
 ABSOLUTE OVERPULL 842,000 lb.  
 TOOL SHIPPING WEIGHT 2238.4 lb

#### MUDLUBE

BIT TO BEND FIXED 51.9"  
 BIT TO BEND ADJ. 63.7"  
 MAX W.O.B. 70,794 lb.  
 O/A LENGTH 322.6'  
 MAX. OVERPULL AND RERUN 295,556 lb.  
 ABSOLUTE OVERPULL 578,657 lb.  
 TOOL SHIPPING WEIGHT 2118.4 lb.

HOLE SIZE 7 7/8" - 9 7/8"  
 BIT BOX CONN. 4 1/2 REG.  
 ADJUSTABLE TORQUE 20,000 ft-lb  
 REV/GAL AT FULL LOAD 0.32  
 REV/GAL AT NO LOAD 0.35

DIFF. PRES. STANDARD 720 psi  
 DIFF. PRES. HARD 1080 psi

### HARD RUBBER

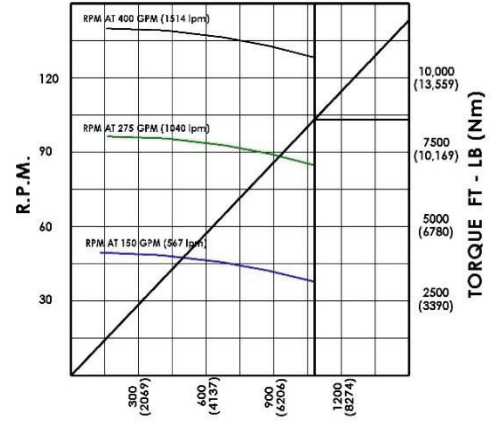

DIFFERENTIAL PRESSURE P.S.I. (kPa)

VOLUME (gpm)	150-400
SPEED (rpm)	38-140
TORQUE AT FULL LOAD (ft-lb)	8620
OUTPUT AT FULL LOAD (hp)	211.7

6 1/4 7-8 4.8 Stg.

**STANDARD RUBBER**

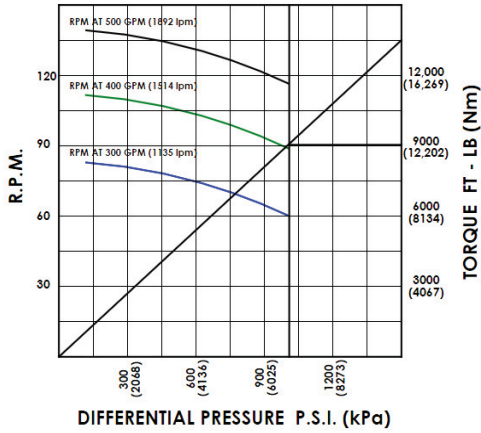

**DIFFERENTIAL PRESSURE P.S.I. (kPa)**

VOLUME (gpm)	300-500
SPEED (rpm)	60-140
TORQUE AT FULL LOAD (ft-lb)	9040
OUTPUT AT FULL LOAD (hp)	201.7

**6 1/4" 7 - 8 6.7 Stg**

SEALED BEARING	
BIT TO BEND FIXED	69.9"
BIT TO BEND ADJ.	58"
MAX W.O.B	76,580 lb.
O/A LENGTH	426.4"
MAX. OVERFULL AND RERUN	219,200 lb.
ABSOLUTE OVERFULL	842,000 lb.
TOOL SHIPPING WEIGHT	2616 lb.
HOLE SIZE	7 7/8" - 9 7/8"
BIT BOX CONN	4 1/2 REG.
ADJUSTABLE TORQUE	20,000 ft-lb
REV/GAL AT FULL LOAD	0.23
REV/ GAL AT NO LAOD	0.28
DIFF. PRES.	1010 psi

**6 1/4 7-8 6.7 Stg.**

### STANDARD RUBBER

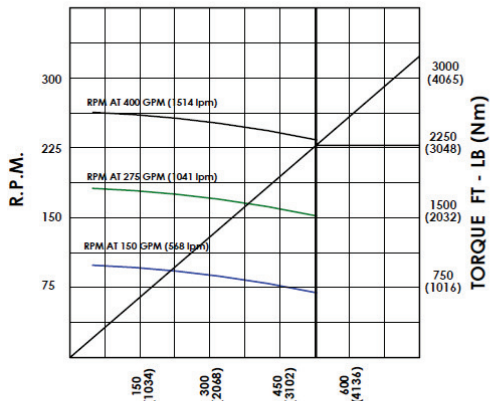

DIFFERENTIAL PRESSURE P.S.I. (kPa)

VOLUME (gpm)	150 - 400
SPEED (rpm)	70 - 243
TORQUE AT FULL LOAD (ft-lb)	2273
OUTPUT AT FULL LOAD (hp)	101

### 6 1/2" - 6 3/4" 4-5 4.3 Stg

**MUD LUBE**  
 BIT TO BEND FIXED 58"  
 BIT TO BEND ADJ. 69.7"  
 MAX. W.O.B. 90,000 lb.  
 O/A LENGTH 252.1"  
 MAX. OVERPULL AND RERUN 404,403 lb.  
 ABSOLUTE OVERPULL 780,000 lb.  
 TOOL SHIPPING WEIGHT 1630 lb.

**SEALED BEARING**  
 BIT TO BEND FIXED 65.5"  
 BIT TO BEND ADJ. 77.4"  
 MAX. W.O.B. 156,000 lb.  
 O/A LENGTH 254.4"  
 MAX. OVERPULL AND RERUN 479,000 lb.  
 ABSOLUTE OVERPULL 650,000 lb.  
 TOOL SHIPPING WEIGHT 1885 lb.

**HOLE SIZE** 7 7/8" - 9 7/8"  
**BIT BOX CONN.** 4 1/2 REG.  
**ADJUSTABLE TORQUE** 20,000 ft-lb  
**REV/GAL AT FULL LOAD** 0.58  
**REV/GAL AT NO LOAD** 0.65

**DIFF. PRES. STANDARD** 529 psi  
**DIFF. PRES. HARD** 661 psi

### HARD RUBBER

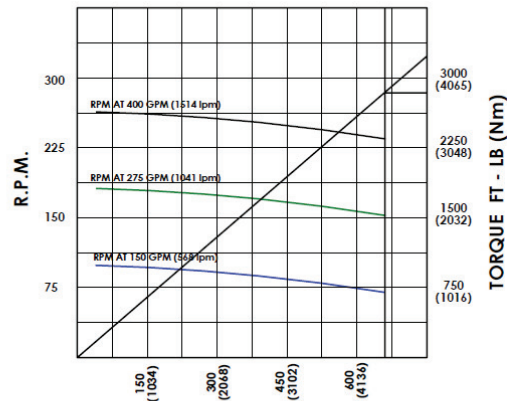

DIFFERENTIAL PRESSURE P.S.I. (kPa)

VOLUME (gpm)	150 - 400
SPEED (rpm)	70 - 263
TORQUE AT FULL LOAD (ft-lb)	2841
OUTPUT AT FULL LOAD (hp)	126.2

6 1/2-6 3/4 4-5 4.3 Stg.



## STANDARD RUBBER

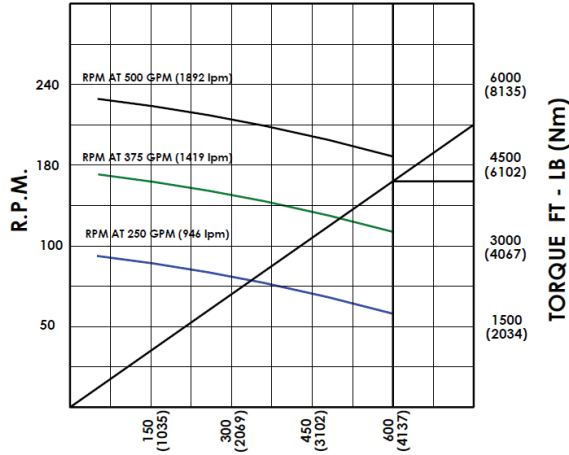

DIFFERENTIAL PRESSURE P.S.I. (kPa)

VOLUME (gpm)	250-500
SPEED (rpm)	58-190
TORQUE AT FULL LOAD (ft-lb)	4200
OUTPUT AT FULL LOAD (hp)	120

6 1/2" - 6 3/4" 5 - 6 4 Stg

**MUD LUBE**  
 BIT TO BEND FIXED 56"  
 BIT TO BEND ADJ. 68"  
 MAX W.O.B. 90,000 lb.  
 O/A LENGTH 294.3"  
 MAX. OVERPULL AND RERUN 406,403 lb.  
 ABSOLUTE OVERPULL 780,000 lb.  
 TOOL SHIPMENT WEIGHT 1781 lb.

**SEALED BEARING**  
 BIT TO BEND FIXED 65.5"  
 BIT TO BEND ADJ. 77.4"  
 MAX W.O.B. 156,000 lb.  
 O/A LENGTH 302.2"  
 MAX. OVERPULL AND RERUN 479,000 lb.  
 ABSOLUTE OVERPULL 650,000 lb.  
 TOOL SHIPMENT WEIGHT 2292 lb.

**HOLE SIZE** 7 7/8" - 9 7/8"  
 BIT BOX CONN. 3 1/2 REG.  
 ADJUSTABLE TORQUE 10,000 ft-lb  
 REV/GAL AT FULL LOAD 0.30  
 REV/ GAL AT NO LOAD 0.38

DIFF. PRES. STANDARD 600 psi

6 1/2" - 6 3/4" 5-6 4 Stg.

**STANDARD RUBBER**

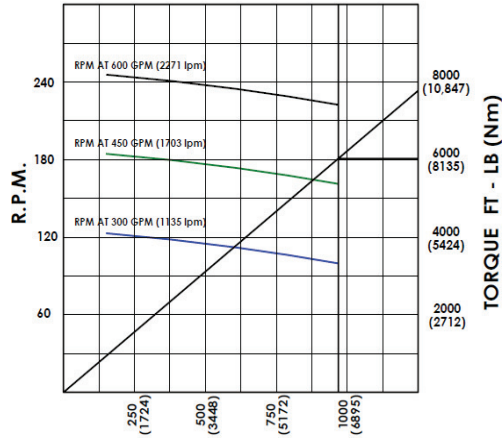

**DIFFERENTIAL PRESSURE P.S.I. (kPa)**

VOLUME (gpm)	300-600
SPEED (rpm)	100-246
TORQUE AT FULL LOAD (ft-lb)	6040
OUTPUT AT FULL LOAD (hp)	256.8

**6 1/2" - 6 3/4" 5 - 6 6.8 Stg**

**MUD LUBE**  
 BIT TO BEND FIXED 56"  
 BIT TO BEND ADJ. 68"  
 MAX W.O.B. 90,000 lb.  
 O/A LENGTH 354"  
 MAX. OVERPULL AND RERUN 406 403 lb.  
 ABSOLUTE OVERPULL 780,000 lb.  
 TOOL SHIPMENT WEIGHT 2849 lb.

**SEALED BEARING**  
 BIT TO BEND FIXED 65.5"  
 BIT TO BEND ADJ. 77.4"  
 MAX W.O.B. 156,000 lb.  
 O/A LENGTH 360"  
 MAX. OVERPULL AND RERUN 479,000 lb.  
 ABSOLUTE OVERPULL 650,000 lb.  
 TOOL SHIPMENT WEIGHT 2925 lb.

**HOLE SIZE** 7 7/8" - 9 7/8"  
**BIT BOX CONN.** 3 1/2 REG.  
**ADJUSTABLE TORQUE**  
 REV/GAL AT FULL LOAD 0.37  
 REV/ GAL AT NO LOAD 0.41

**DIFF. PRES. STANDARD** 970 psi  
**DIFF. PRES. HARD** 1455 psi

**HARD RUBBER**

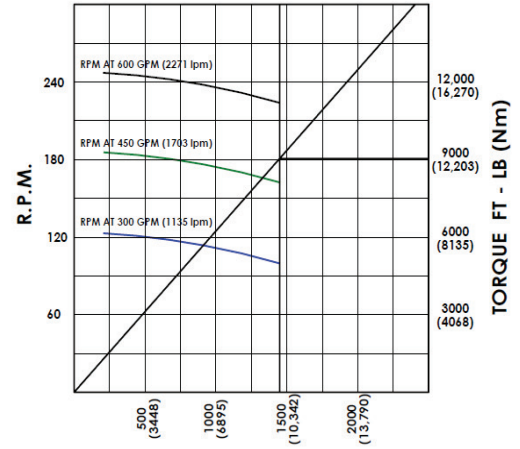

**DIFFERENTIAL PRESSURE P.S.I. (kPa)**

VOLUME (gpm)	300-600
SPEED (rpm)	100-246
TORQUE AT FULL LOAD (ft-lb)	9059
OUTPUT AT FULL LOAD (hp)	385.3

**6 1/2" - 6 3/4" 5-6 6.8 Stg.**

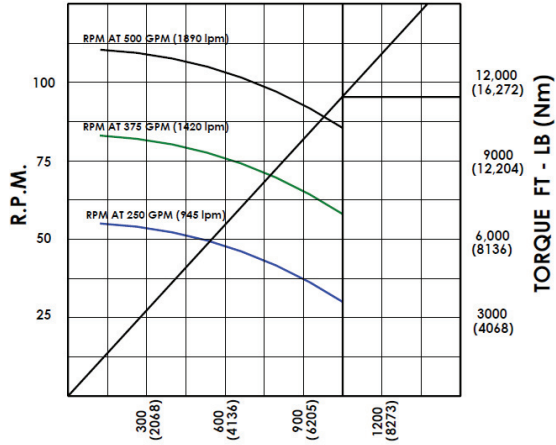

**DIFFERENTIAL PRESSURE P.S.I. (kPa)**

VOLUME (gpm)	250-500
SPEED (rpm)	30-110
TORQUE AT FULL LOAD (ft-lb)	11450
OUTPUT AT FULL LOAD (hp)	187.8

**6 1/2" - 6 3/4" 6 - 7 2.7 Stg EW**

**MUD LUBE**  
 BIT TO BEND FIXED 58"  
 BIT TO BEND ADJ. 69.6"  
 MAX W.O.B. 90,000 lb.  
 O/A LENGTH 354.8"  
 MAX. OVERPULL AND RERUN 406,403 lb.  
 ABSOLUTE OVERPULL 780,000 lb.  
 TOOL SHIPPING WEIGHT 2485 lb.

**SEALED BEARING**  
 BIT TO BEND FIXED 65.5"  
 BIT TO BEND ADJ. 77.4"  
 MAX W.O.B. 156,000 lb.  
 O/A LENGTH 362.6"  
 MAX OVERPULL AND RERUN 479,000 lb.  
 ABSOLUTE OVERPULL 650,000 lb.  
 TOOL SHIPPING WEIGHT 2745 lb.

**HOLE SIZE** 7 7/8" - 9 7/8"  
 BIT BOX CONN. 4 1/2 REG.  
 ADJUSTABLE TORQUE 20,000 ft-lb  
 REV/ GAL AT FULL LOAD 0.17  
 REV/ GAL AT NO LOAD 0.22

DIFF. PRES. 1050 psi

# 6 1/2" - 6 3/4" 6 - 7 2.9 Stg EW

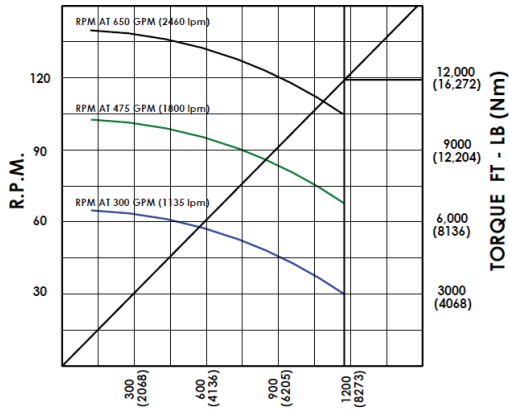

DIFFERENTIAL PRESSURE P.S.I. (kPa)

VOLUME (gpm)	300-650
SPEED (rpm)	30-140
TORQUE AT FULL LOAD (ft-lb)	11950
OUTPUT AT FULL LOAD (hp)	257.5

MUD LUBE  
 BIT TO BEND FIXED 56"  
 BIT TO BEND ADJ. 68"  
 MAX W.O.B. 90,000 lb.  
 O/A LENGTH 329"  
 MAX. OVERPULL AND RERUN 406,403 lb.  
 ABSOLUTE OVERPULL 780,000 lb.  
 TOOL SHIPPING WEIGHT 2416 lb.

SEALED BEARING  
 BIT TO BEND FIXED 65.5"  
 BIT TO BEND ADJ. 77.4"  
 MAX W.O.B. 156,000 lb.  
 O/A LENGTH 338.6"  
 MAX OVERPULL AND RERUN 479,000 lb.  
 ABSOLUTE OVERPULL 650,000 lb.  
 TOOL SHIPPING WEIGHT 2518 lb.

HOLE SIZE 7 7/8" - 9 7/8"  
 BIT BOX CONN. 3 1/2 REG.  
 ADJUSTABLE TORQUE 10,000 ft-lb  
 REV/ GAL AT FULL LOAD 0.17  
 REV/ GAL AT NO LOAD 0.21

DIFF. PRES. 1175 psi

6 1/2" - 6 3/4" 6-7 2.9 Stg.

# 6 1/2"- 6 3/4" 6-7 4.8 Stg EW

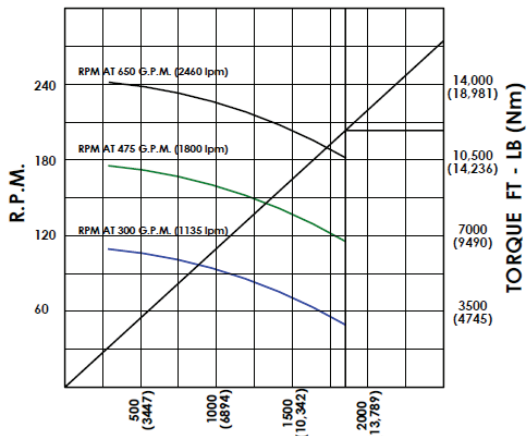

DIFFERENTIAL PRESSURE P.S.I. (kPa)

VOLUME (gpm)	300-650
SPEED (rpm)	50-240
TORQUE AT FULL LOAD (ft-lb)	11,880
OUTPUT AT FULL LOAD (hp)	407.8

- MUD LUBE**
- BIT TO BEND FIXED 56"
- BIT TO BEND ADJ. 68"
- MAX W.O.B. 90,000 lb.
- O/A LENGTH 329"
- MAX. OVERPULL AND RERUN 406,403 lb.
- ABSOLUTE OVERPULL 780,000 lb.
- TOOL SHIPPING WEIGHT 2529 lb.
  
- SEALED BEARING**
- BIT TO BEND FIXED 65.5"
- BIT TO BEND ADJ. 77.4"
- MAX W.O.B. 156,000 lb.
- O/A LENGTH 334.3"
- MAX OVERPULL AND RERUN 479,000 lb.
- ABSOLUTE OVERPULL 650,000 lb.
- TOOL SHIPPING WEIGHT 2631.6 lb.
  
- HOLE SIZE** 7 7/8" - 9 7/8"
- BIT BOX CONN. 3 1/2 REG.
- ADJUSTABLE TORQUE 10,000 ft-lb
- REV/GAL AT FULL LOAD 0.27
- REV/GAL AT NO LOAD 0.36
  
- DIFF. PRES. 11,880 psi

6 1/2 - 6 3/4 6-7 4.8 Stg.

**STANDARD RUBBER**

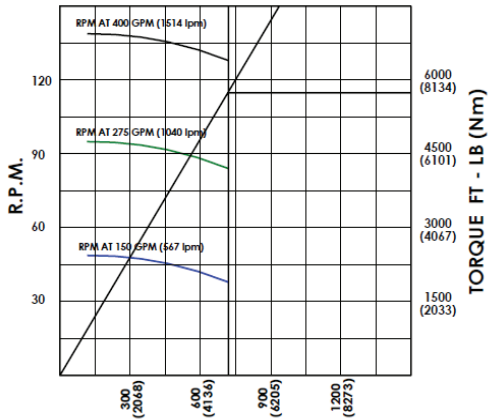

**DIFFERENTIAL PRESSURE P.S.I. (kPa)**

VOLUME (gpm)	150-400
SPEED (rpm)	38-140
TORQUE AT FULL LOAD (ft-lb)	5740
OUTPUT AT FULL LOAD (hp)	139

**6 1/2" 7 - 8 4.8 Stg**

**MUD LUBE**  
 BIT TO BEND FIXED 58"  
 BIT TO BEND ADJ. 49.6"  
 MAX W.O.B. 90,000 lb.  
 O/A LENGTH 328.3"  
 MAX. OVERPULL AND RERUN 406,405 lb.  
 ABSOLUTE OVERPULL 780,000 lb.  
 TOOL SHIPPING WEIGHT 2258 lb.

**SEALED BEARING**  
 BIT TO BEND FIXED 45.6"  
 BIT TO BEND ADJ. 77.5"  
 MAX W.O.B. 156,000 lb.  
 O/A LENGTH 336.1"  
 MAX. OVERPULL AND RERUN 479,000 lb.  
 ABSOLUTE OVERPULL 650,000 lb.  
 TOOL SHIPPING WEIGHT 2517 lb.

**HOLE SIZE** 7 7/8" - 9 7/8"  
 BIT BOX CONN. 4 1/2 REG.  
 ADJUSTABLE TORQUE 20,000 ft-lb  
 REV/GAL AT FULL LOAD 0.31  
 REV/GAL AT NO LOAD 0.35

DIFF. PRES. STANDARD 720 psi  
 DIFF. PRES. HARD 1080 psi

**HARD RUBBER**

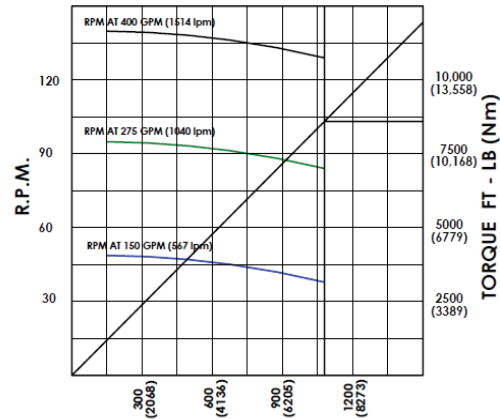

**DIFFERENTIAL PRESSURE P.S.I. (kPa)**

VOLUME (gpm)	150-400
SPEED (rpm)	38-140
TORQUE AT FULL LOAD (ft-lb)	8620
OUTPUT AT FULL LOAD (hp)	208.7

**6 1/2 - 6 3/4 7-8 4.8 Stg.**

**STANDARD RUBBER**

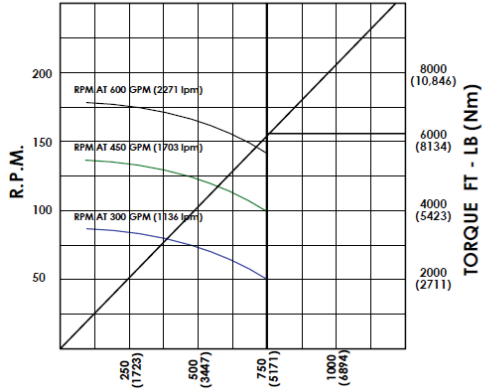

**DIFFERENTIAL PRESSURE P.S.I. (kPa)**

VOLUME (gpm)	300-600
SPEED (rpm)	50-180
TORQUE AT FULL LOAD (ft-lb)	6230
OUTPUT AT FULL LOAD (hp)	170

**6 1/2" - 6 3/4" 6 - 7 5 Stg**

**MUD LUBE**  
 BIT TO BEND FIXED 58"  
 BIT TO BEND ADJ. 69.7"  
 MAX W.O.B. 90,000 lb.  
 O/A LENGTH 324.8"  
 MAX. OVERPULL AND RERUN 406,403 lb.  
 ABSOLUTE OVERPULL 780,000 lb.  
 TOOL SHIPPING WEIGHT 2054 lb.

**SEALED BEARING**  
 BIT TO BEND FIXED 65.5"  
 BIT TO BEND ADJ. 77.4"  
 MAX W.O.B. 156,000 lb.  
 O/A LENGTH 332.6"  
 MAX. OVERPULL AND RERUN 479,000 lb.  
 ABSOLUTE OVERPULL 650,000 lb.  
 TOOL SHIPPING WEIGHT 2313.3 lb.

**HOLE SIZE** 7 7/8" - 9 7/8"  
 BIT BOX CONN. 4 1/2 REG.  
 ADJUSTABLE TORQUE 20,000 ft-lb  
 REV/GAL AT FULL LOAD 0.23  
 REV/GAL AT NO LOAD 0.30

DIFF. PRES. STANDARD 750 psi  
 DIFF. PRES. HARD 1130 psi

**HARD RUBBER**

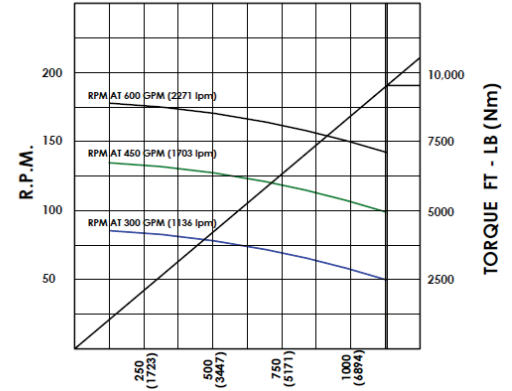

**DIFFERENTIAL PRESSURE P.S.I. (kPa)**

VOLUME (gpm)	300-600
SPEED (rpm)	50-180
TORQUE AT FULL LOAD (ft-lb)	9350
OUTPUT AT FULL LOAD (hp)	255

**6 1/2" - 6 3/4" 6-7 5 Stg.**

**STANDARD RUBBER**

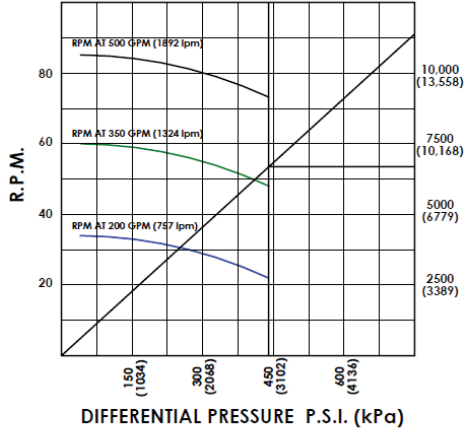

**DIFFERENTIAL PRESSURE P.S.I. (kPa)**

VOLUME (gpm)	200-500
SPEED (rpm)	22-85
TORQUE AT FULL LOAD (ft-lb)	6400
OUTPUT AT FULL LOAD (hp)	89.1

**6 1/2" - 6 3/4" 7 - 8 2.9 Stg**

**MUD LUBE**  
 BIT TO BEND FIXED 58"  
 BIT TO BEND ADJ. 69.7"  
 MAX W.O.B. 90,000 lb.  
 O/A LENGTH 353.6"  
 MAX. OVERPULL AND RERUN 406,403 lb.  
 ABSOLUTE OVERPULL 750,000 lb.  
 TOOL SHIPPING WEIGHT 2319 lb.

**SEALED BEARING**  
 BIT TO BEND FIXED 65.5"  
 BIT TO BEND ADJ. 77.4"  
 MAX W.O.B. 150,000 lb.  
 O/A LENGTH 381.4"  
 MAX. OVERPULL AND RERUN 479,000 lb.  
 ABSOLUTE OVERPULL 650,000 lb.  
 TOOL SHIPPING WEIGHT 2578.3lb.

**HOLE SIZE** 7 7/8" - 9 7/8"  
**BIT BOX CONN.** 4 1/2 REG.  
**ADJUSTABLE TORQUE** 20,000 ft-lb  
**REV/ GAL AT FULL LOAD** 0.14  
**REV/ GAL AT NO LAOD** 0.17

**DIFF. PRES. STANDARD** 440 psi  
**DIFF. PRES. HARD** 650 psi

**HARD RUBBER**

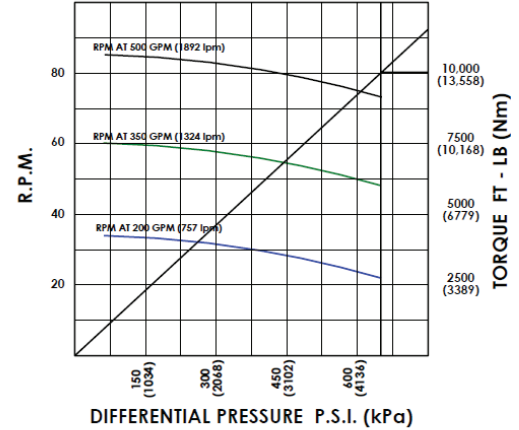

**DIFFERENTIAL PRESSURE P.S.I. (kPa)**

VOLUME (gpm)	200-500
SPEED (rpm)	22-85
TORQUE AT FULL LOAD (ft-lb)	9600
OUTPUT AT FULL LOAD (hp)	133.6

**6 1/2 - 6 3/4 7-8 2.9 Stg.**



6 1/2" - 6 3/4" 7 - 8 2.9 Stg

**MUD LUBE**  
 BIT TO BEND FIXED 56"  
 BIT TO BEND ADJ. 68"  
 MAX W.O.B. 90,000 lb.  
 O/A LENGTH 350.8"  
 MAX. OVERPULL AND RERUN 406,403 lb.  
 ABSOLUTE OVERPULL 780,000 lb.  
 TOOL SHIPMENT WEIGHT 2579 lb.

**SEALED BEARING**  
 BIT TO BEND FIXED 65.5"  
 BIT TO BEND ADJ. 77.4"  
 MAX W.O.B. 156,000 lb.  
 O/A LENGTH 358.6"  
 MAX. OVERPULL AND RERUN 479,000 lb.  
 ABSOLUTE OVERPULL 650,000 lb.  
 TOOL SHIPMENT WEIGHT 2655 lb.

**HOLE SIZE** 7 7/8" - 9 7/8"  
**BIT BOX CONN.** 3 1/2 REG.  
**ADJUSTABLE TORQUE** 10,000 ft-lb  
**REV/GAL AT FULL LOAD** 0.13  
**REV/ GAL AT NO LOAD** 0.16

**DIFF. PRES. HARD** 725 psi

HARD RUBBER

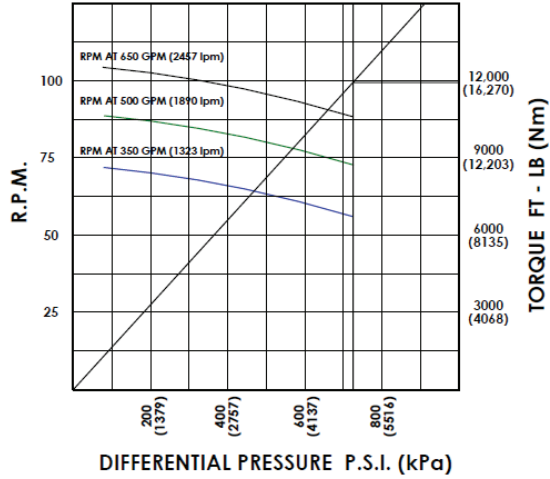

DIFFERENTIAL PRESSURE P.S.I. (kPa)

VOLUME (gpm)	350-650
SPEED (rpm)	56-104
TORQUE AT FULL LOAD (ft-lb)	11,929
OUTPUT AT FULL LOAD (hp)	199.8

**STANDARD RUBBER**

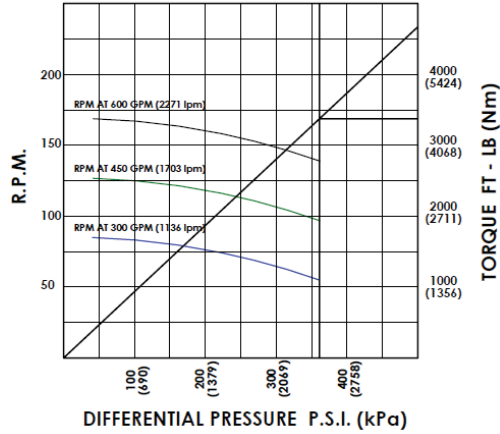

VOLUME (gpm)	300-600
SPEED (rpm)	55-168
TORQUE AT FULL LOAD (ft-lb)	3374
OUTPUT AT FULL LOAD (hp)	88.6

**6 1/2" - 6 3/4" 7 - 8 3.0 Stg**

**MUD LUBE**  
 BIT TO BEND FIXED 58"  
 BIT TO BEND ADJ. 69.7"  
 MAX W.O.B. 90,000 lb.  
 O/A LENGTH 275.9"  
 MAX. OVERPULL AND RERUN 406,403 lb.  
 ABSOLUTE OVERPULL 780,000 lb.  
 TOOL SHIPPING WEIGHT 2085 lb.

**SEALED BEARING**  
 BIT TO BEND FIXED 65.5"  
 BIT TO BEND ADJ. 77.4"  
 MAX W.O.B. 150,000 lb.  
 O/A LENGTH 283.6"  
 MAX. OVERPULL AND RERUN 479,000 lb.  
 ABSOLUTE OVERPULL 650,000 lb.  
 TOOL SHIPPING WEIGHT 2161 lb.

**HOLE SIZE** 7 7/8" - 9 7/8"  
 BIT BOX CONN. 4 1/2 REG.  
 ADJUSTABLE TORQUE 20,000 ft-lb  
 REV/GAL AT FULL LOAD 0.23  
 REV/GAL AT NO LAOD 0.28

DIFF. PRES. STANDARD 361 psi  
 DIFF. PRES. HARD 451 psi

**HARD RUBBER**

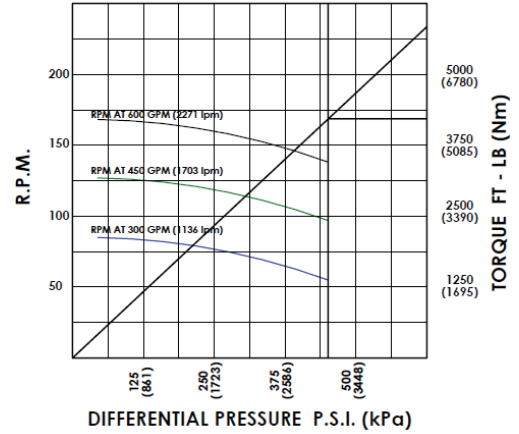

VOLUME (gpm)	300-600
SPEED (rpm)	55-168
TORQUE AT FULL LOAD (ft-lb)	4218
OUTPUT AT FULL LOAD (hp)	110.8

**6 1/2 - 6 3/4 7-8 3.0 Stg.**

**STANDARD RUBBER**

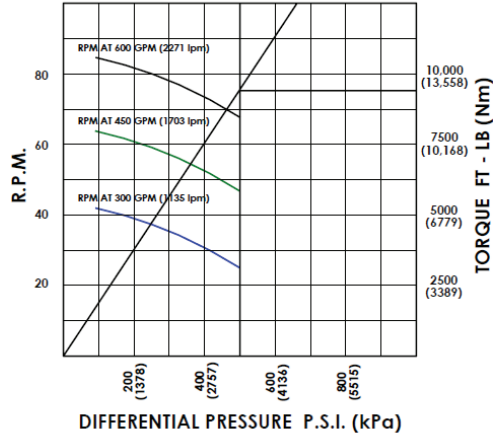

VOLUME (gpm)	300-600
SPEED (rpm)	25-84
TORQUE AT FULL LOAD (ft-lb)	9410
OUTPUT AT FULL LOAD (hp)	121

**6 1/2" - 6 3/4" 7 - 8 3.3 Stg**

**MUD LUBE**  
 BIT TO BEND FIXED 58"  
 BIT TO BEND ADJ. 69.7"  
 MAX W.O.B. 90,000 lb.  
 O/A LENGTH 36.9.8"  
 MAX. OVERPULL AND RERUN 406,403 lb.  
 ABSOLUTE OVERPULL 780,000 lb.  
 TOOL SHIPPING WEIGHT 2452 lb.

**SEALED BEARING**  
 BIT TO BEND FIXED 65.5"  
 BIT TO BEND ADJ. 77.4"  
 MAX W.O.B. 156,000 lb.  
 O/A LENGTH 377.62"  
 MAX. OVERPULL AND RERUN 479,000 lb.  
 ABSOLUTE OVERPULL 650,000 lb.

**HOLE SIZE** 7 7/8" - 9 7/8"  
 BIT BOX CONN. 4 1/2 REG.  
 ADJUSTABLE TORQUE 20,000 ft-lb  
 REV/GAL AT FULL LOAD 0.11  
 REV/GAL AT NO LOAD 0.14

**DIFF. PRES. STANDARD** 500 psi  
**DIFF. PRES. HARD** 740 psi

**HARD RUBBER**

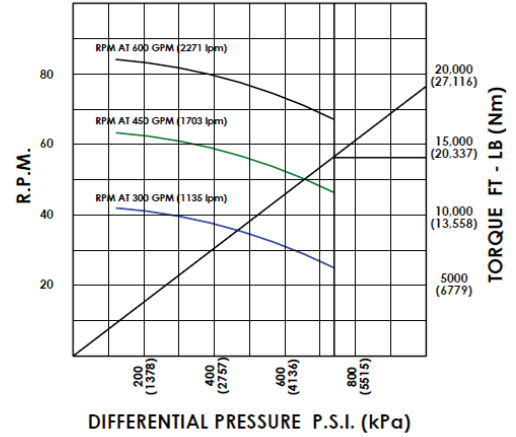

VOLUME (gpm)	300-600
SPEED (rpm)	25-84
TORQUE AT FULL LOAD (ft-lb)	14110
OUTPUT AT FULL LOAD (hp)	169.5

**6 1/2 - 6 3/4 7-8 3.3 Stg.**

# 6 1/2" - 6 3/4" 7 - 8 3.4 Stg DEW

**MUD LUBE**  
 BIT TO BEND FIXED 56"  
 BIT TO BEND ADJ. 68"  
 MAX W.O.B. 90,000 lb.  
 O/A LENGTH 299.9"  
 MAX. OVERPULL AND RERUN 406,403 lb.  
 ABSOLUTE OVERPULL 780,000 lb.  
 TOOL SHIPMENT WEIGHT 2407 lb.

**SEALED BEARING**  
 BIT TO BEND FIXED 65.5"  
 BIT TO BEND ADJ. 77.4"  
 MAX W.O.B. 156,000 lb.  
 O/A LENGTH 307.6"  
 MAX. OVERPULL AND RERUN 479,000 lb.  
 ABSOLUTE OVERPULL 650,000 lb.  
 TOOL SHIPMENT WEIGHT 2483 lb.

**HOLE SIZE** 7 7/8" - 9 7/8"  
 BIT BOX CONN. 3 1/2 REG.  
 ADJUSTABLE TORQUE 10,000 ft-lb  
 REV/GAL AT FULL LOAD 0.25  
 REV/GAL AT NO LOAD 0.27

**DIFF. PRES.** 1550 psi

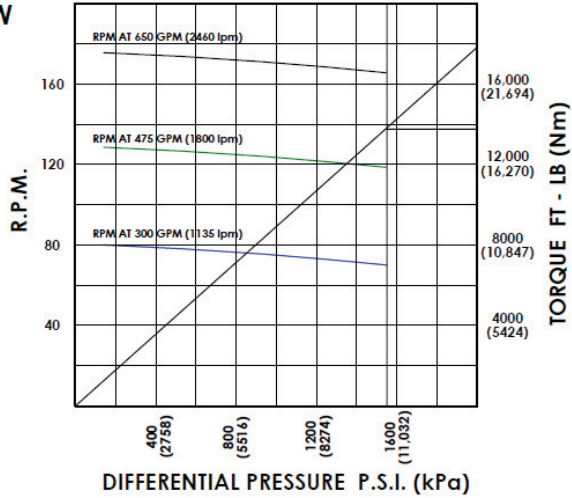

VOLUME (gpm)	300-650
SPEED (rpm)	70-175
TORQUE AT FULL LOAD (ft-lb)	13,760
OUTPUT AT FULL LOAD (hp)	432.3

6 1/2" - 6 3/4" 7-8 3.4 Stg.

### STANDARD RUBBER

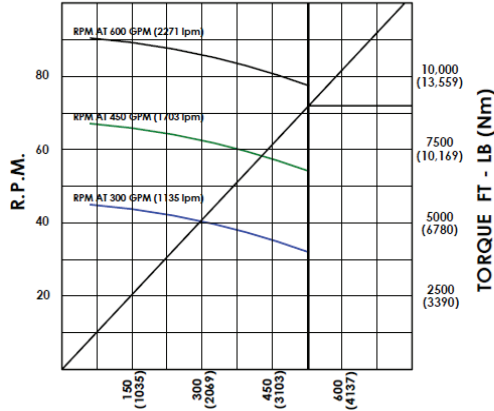

#### DIFFERENTIAL PRESSURE P.S.I. (kPa)

VOLUME (gpm)	300-600
SPEED (rpm)	32-90
TORQUE AT FULL LOAD (ft-lb)	9000
OUTPUT AT FULL LOAD (hp)	133.1

### 6 1/2" - 6 3/4" 7 - 8 3.5 Stg

**MUD LUBE**  
 BIT TO BEND FIXED 56"  
 BIT TO BEND ADJ. 68"  
 MAX W.O.B. 90,000 lb.  
 O/A LENGTH 384.9'  
 MAX. OVERPULL AND RERUN 406,403 lb.  
 ABSOLUTE OVERPULL 780,000 lb.  
 TOOL SHIPMENT WEIGHT 2978 lb.

**SEALED BEARING**  
 BIT TO BEND FIXED 65.5"  
 BIT TO BEND ADJ. 77.4"  
 MAX W.O.B. 186,000 lb.  
 O/A LENGTH 392.6'  
 MAX. OVERPULL AND RERUN 479,000 lb.  
 ABSOLUTE OVERPULL 650,000 lb.  
 TOOL SHIPMENT WEIGHT 2839 lb.

**HOLE SIZE** 7 7/8" - 9 7/8"  
 BIT BOX CONN. 3 1/2 REG.  
 ADJUSTABLE TORQUE 10,000 ft-lb  
 REV/ GAL AT FULL LOAD 0.13  
 REV/ GAL AT NO LOAD 0.15

DIFF. PRES. STANDARD 530 psi  
 DIFF. PRES. HARD 790 psi

### HARD RUBBER

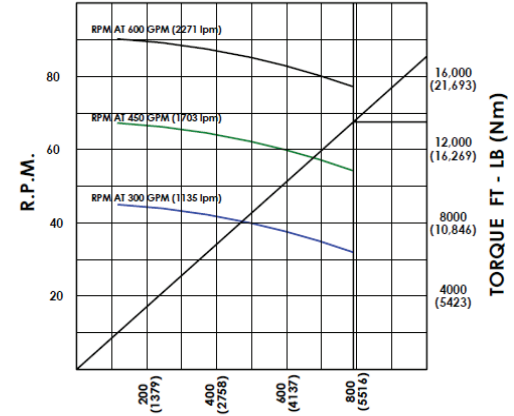

#### DIFFERENTIAL PRESSURE P.S.I. (kPa)

VOLUME (gpm)	300-600
SPEED (rpm)	32-90
TORQUE AT FULL LOAD (ft-lb)	13500
OUTPUT AT FULL LOAD (hp)	199.5

6 1/2" - 6 3/4" 7-8 3.5 Stg.

### STANDARD RUBBER

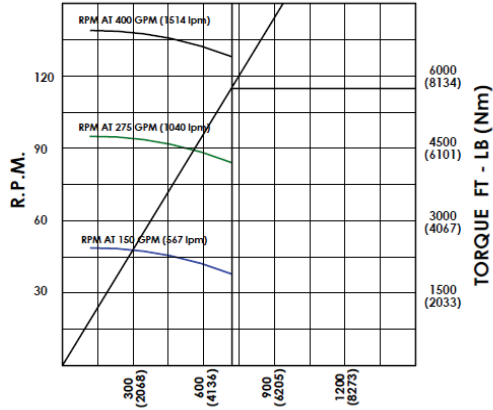

DIFFERENTIAL PRESSURE P.S.I. (kPa)

VOLUME (gpm)	150-400
SPEED (rpm)	38-140
TORQUE AT FULL LOAD (ft-lb)	5740
OUTPUT AT FULL LOAD (hp)	139

6 1/2" - 6 3/4" 7 - 8 4.8 Stg

#### MUD LUBE

BIT TO BEND FIXED 58"  
 BIT TO BEND ADJ. 69.6"  
 MAX W.O.B. 90,000 lb.  
 O/A LENGTH 328.3"  
 MAX. OVERPULL AND RERUN 406,405 lb.  
 ABSOLUTE OVERPULL 780,000 lb.  
 TOOL SHIPPING WEIGHT 2258 lb.

#### SEALED BEARING

BIT TO BEND FIXED 65.6"  
 BIT TO BEND ADJ. 77.5"  
 MAX W.O.B. 156,000 lb.  
 O/A LENGTH 336.1"  
 MAX. OVERPULL AND RERUN 479,000 lb.  
 ABSOLUTE OVERPULL 650,000 lb.  
 TOOL SHIPPING WEIGHT 2517 lb.

HOLE SIZE 7 7/8" - 9 7/8"  
 BIT BOX CONN. 4 1/2 REG.  
 ADJUSTABLE TORQUE 20,000 ft-lb  
 REV/GAL AT FULL LOAD 0.31  
 REV/GA AT NO LOAD 0.35

DIFF. PRES. STANDARD  
 DIFF. PRES. HARD

720 psi  
 1080 psi

### HARD RUBBER

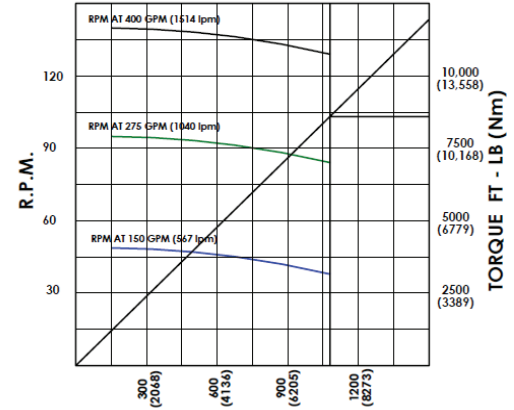

DIFFERENTIAL PRESSURE P.S.I. (kPa)

VOLUME (gpm)	150-400
SPEED (rpm)	38-140
TORQUE AT FULL LOAD (ft-lb)	8620
OUTPUT AT FULL LOAD (hp)	208.7

6 1/2" - 6 3/4" 7-8 4.8 Stg.

**STANDARD RUBBER**

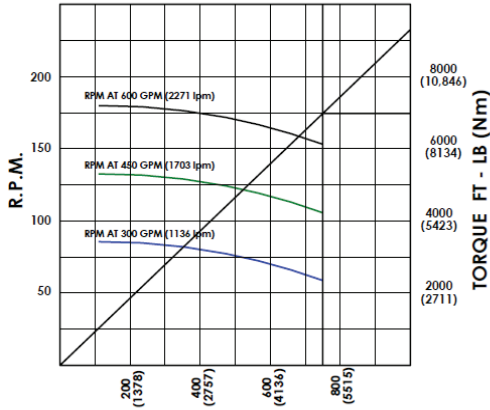

**DIFFERENTIAL PRESSURE P.S.I. (kPa)**

VOLUME (gpm)	300-600
SPEED (rpm)	59-180
TORQUE AT FULL LOAD (ft-lb)	6980
OUTPUT AT FULL LOAD (hp)	224.5

**6 1/2" - 6 3/4" 7 - 8 5.0 Stg**

**MUD LUBE**  
 BIT TO BEND FIXED 58"  
 BIT TO BEND ADJ. 69.7"  
 MAX. W.O.B. 90,000 lb.  
 O/A LENGTH 319.3"  
 MAX. OVERPULL AND RERUN 406,403 lb.  
 ABSOLUTE OVERPULL 780,000 lb.  
 TOOL SHIPPING WEIGHT 1543 lb.

**SEALED BEARING**  
 BIT TO BEND FIXED 65.5"  
 BIT TO BEND ADJ. 77.4"  
 MAX. W.O.B. 156,000 lb.  
 O/A LENGTH 327.1"  
 MAX. OVERPULL AND RERUN 479,000 lb.  
 ABSOLUTE OVERPULL 650,000 lb.  
 TOOL SHIPPING WEIGHT 2042.3 lb.

**HOLE SIZE** 7 7/8" - 9 7/8"  
**BIT BOX CONN.** 4 1/2 REG.  
**ADJUSTABLE TORQUE** 20,000 ft-lb  
**REV/GAL AT FULL LOAD** 0.25  
**REV/GAL AT NO LOAD** 0.30

DIFF. PRES. STANDARD 750 psi  
 DIFF. PRES. HARD 1130 psi

**HARD RUBBER**

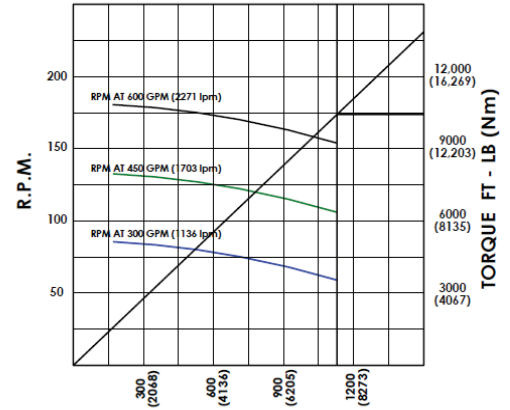

**DIFFERENTIAL PRESSURE P.S.I. (kPa)**

VOLUME (gpm)	300-600
SPEED (rpm)	59-180
TORQUE AT FULL LOAD (ft-lb)	10460
OUTPUT AT FULL LOAD (hp)	336.5

**6 1/2 - 6 3/4 7-8 5.0 Stg.**

# 6 1/2" - 6 3/4" 7 - 8 5.0 Stg EW

**MUD LUBE**  
 BIT TO BEND FIXED 56"  
 BIT TO BEND ADJ. 48"  
 MAX W.O.B. 90,000 lb.  
 O/A LENGTH 369.8"  
 MAX. OVERPULL AND RERUN 406,403 lb.  
 ABSOLUTE OVERPULL 780,000 lb.  
 TOOL SHIPMENT WEIGHT 2987 lb.

**SEALED BEARING**  
 BIT TO BEND FIXED 65.5"  
 BIT TO BEND ADJ. 77.4"  
 MAX W.O.B. 156,000 lb.  
 O/A LENGTH 377.5"  
 MAX. OVERPULL AND RERUN 479,000 lb.  
 ABSOLUTE OVERPULL 650,000 lb.  
 TOOL SHIPMENT WEIGHT 3063 lb.

**HOLE SIZE** 7 7/8" - 9 7/8"  
**BIT BOX CONN.** 3 1/2 REG.  
**ADJUSTABLE TORQUE** 10,000 ft-lb  
**REV/GAL AT FULL LOAD** 0.27  
**REV/ GAL AT NO LOAD** 0.28

**DIFF. PRES. HARD** 1400 psi

## HARD RUBBER

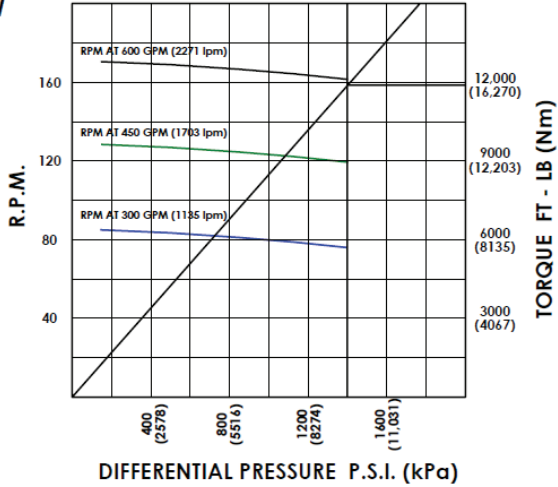

VOLUME (gpm)	300-600
SPEED (rpm)	76-170
TORQUE AT FULL LOAD (ft-lb)	11,917
OUTPUT AT FULL LOAD (hp)	367.5

6 1/2" - 6 3/4" 7-8 5.0 Stg.



### STANDARD RUBBER

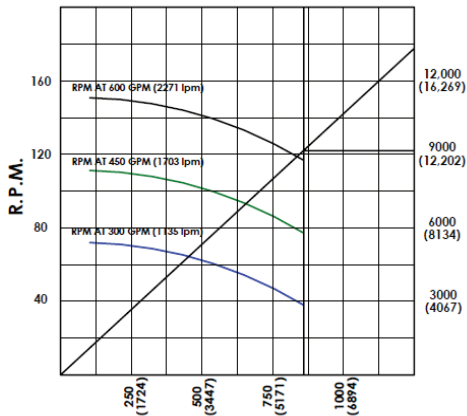

### DIFFERENTIAL PRESSURE P.S.I. (kPa)

VOLUME (gpm)	300-600 (1135-2271 lpm)
SPEED (rpm)	38-150
TORQUE AT FULL LOAD (ft-lb)	9150 (12405 Nm)
OUTPUT AT FULL LOAD (hp)	204.1 (150.1 kW)

### 6 1/2" - 6 3/4" 7 - 8 5.7 Stg

**MUD LUBE**

BIT TO BEND FIXED 54" (1422 mm)  
 BIT TO BEND ADJ. 48" (1274 mm)  
 MAX W.O.B. 90,000 lb. (40823 Kg)  
 O/A LENGTH 387" (9829 mm)  
 MAX. OVERPULL AND RERUN 406,403 lb. (184341 Kg)  
 ABSOLUTE OVERPULL 780,000 lb. (353802 Kg)  
 TOOL SHIPMENT WEIGHT 2824 lb. (1281 Kg)

**SEALED BEARING**

BIT TO BEND FIXED 65.5" (1663 mm)  
 BIT TO BEND ADJ. 77.4" (1966 mm)  
 MAX W.O.B. 156,000 lb. (70760 kg)  
 O/A LENGTH 392.6" (9972 mm)  
 MAX. OVERPULL AND RERUN 479,000 lb. (217270 Kg)  
 ABSOLUTE OVERPULL 850,000 lb. (294835 Kg)  
 TOOL SHIPMENT WEIGHT 2930.6 lb. (1330 Kg)

HOLE SIZE 7 7/8" - 9 7/8" (200 - 244.3 mm)  
 BIT BOX CONN. 3 1/2 REG.  
 ADJUSTABLE TORQUE 10,000 ft-lb (13558 Nm)  
 REV/GAL AT FULL LOAD 0.19 (.050 Rev/Lit)  
 REV/GAL AT NO LOAD 0.25 (.066 Rev/Lit)

DIFF. PRES. STANDARD 860 psi (5929 kPa)  
 DIFF. PRES. HARD 1280 psi (8825 kPa)

### HARD RUBBER

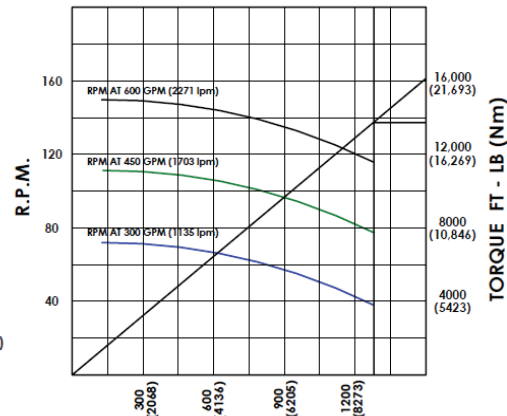

### DIFFERENTIAL PRESSURE P.S.I. (kPa)

VOLUME (gpm)	300-600 (1135-2271 lpm)
SPEED (rpm)	38-150
TORQUE AT FULL LOAD (ft-lb)	13720 (18601 Nm)
OUTPUT AT FULL LOAD (hp)	306.1 (225.1 kW)

6 1/2" - 6 3/4" 7-8 5.7 Stg.

**STANDARD RUBBER**

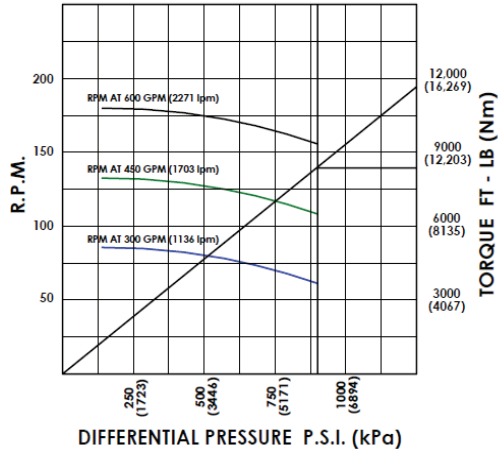

**DIFFERENTIAL PRESSURE P.S.I. (kPa)**

VOLUME (gpm)	300-600
SPEED (rpm)	59-180
TORQUE AT FULL LOAD (ft-lb)	8370
OUTPUT AT FULL LOAD (hp)	244.2

**6 1/2" - 6 3/4" 7-8 6.0 Stg**

- MUD LUBE**
  - BIT TO BEND FIXED 58"
  - BIT TO BEND ADJ. 69.7"
  - MAX W.O.B. 90,000 lb.
  - O/A LENGTH 356.8'
  - MAX. OVERPULL AND RERUN 406,403 lb.
  - ABSOLUTE OVERPULL 780,000 lb.
  - TOOL SHIPPING WEIGHT 2363 lb.
- SEALED BEARING**
  - BIT TO BEND FIXED 65.5"
  - BIT TO BEND ADJ. 77.4"
  - MAX W.O.B. 156,000 lb.
  - O/A LENGTH 364.6'
  - MAX. OVERPULL AND RERUN 479,000 lb.
  - ABSOLUTE OVERPULL 650,000 lb.
  - TOOL SHIPPING WEIGHT 2642.3 lb.
- SHORT BIT TO BEND**
  - BIT TO BEND FIXED 44.1"
  - BIT TO BEND ADJ. 56.5"
  - ON BOTTOM WOB 100,000 lb.
  - OFF BOTTOM WOB 100,000 lb.
  - MAX. OVERPULL AND RERUN 90,000 lb.
  - ABSOLUTE OVERPULL 500,000 lb.
  - TOOL SHIPPING WEIGHT 2178 lb.
- HOLE SIZE** 7 7/8" - 9 7/8"
- BIT BOX CONN. 4 1/2 REG.
- ADJUSTABLE TORQUE 20,000 ft-lb
- REV/GAL AT FULL LOAD 0.25
- REV/ GAL AT NO LOAD 0.30
- DIFF. PRES. STANDARD** 900 psi
- DIFF. PRES. HARD** 1350 psi

**HARD RUBBER**

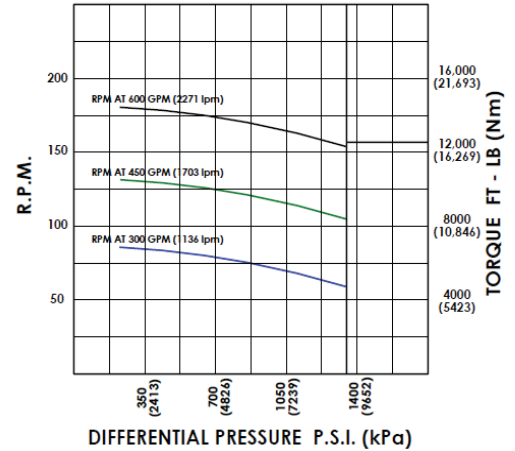

**DIFFERENTIAL PRESSURE P.S.I. (kPa)**

VOLUME (gpm)	300-600
SPEED (rpm)	59-180
TORQUE AT FULL LOAD (ft-lb)	12560
OUTPUT AT FULL LOAD (hp)	366.5

**6 1/2 - 6 3/4 7-8 6.0 Stg.**

## STANDARD RUBBER

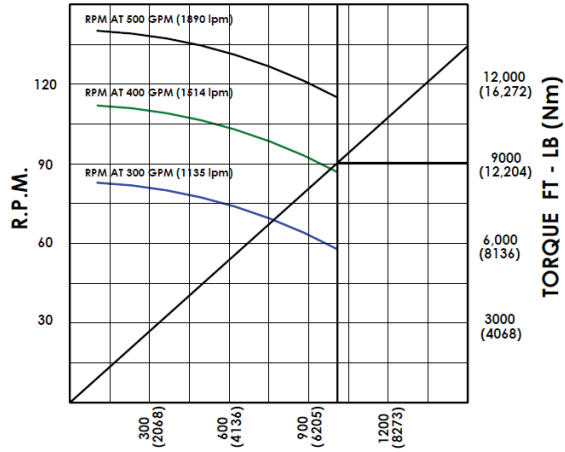

DIFFERENTIAL PRESSURE P.S.I. (kPa)

VOLUME (gpm)	300-500
SPEED (rpm)	58-140
TORQUE AT FULL LOAD (ft-lb)	9040
OUTPUT AT FULL LOAD (hp)	193.1

6 1/2" - 6 3/4" 7 - 8 6.7 Stg

MUD LUBE  
 BIT TO BEND FIXED 58"  
 BIT TO BEND ADJ. 89.6"  
 MAX W.O.B. 90,000 lb.  
 O/A LENGTH 424.6"  
 MAX. OVERPULL AND RERUN 406,403 lb.  
 ABSOLUTE OVERPULL 780,000 lb.  
 TOOL SHIPPING WEIGHT 2874 lb.

SEALED BEARING  
 BIT TO BEND FIXED 65.5"  
 BIT TO BEND ADJ. 77.4"  
 MAX W.O.B. 156,000 lb.  
 O/A LENGTH 431.6"  
 MAX OVERPULL AND RERUN 479,000 lb.  
 ABSOLUTE OVERPULL 650,000 lb.  
 TOOL SHIPPING WEIGHT 3106.3 lb.

HOLE SIZE 7 7/8" - 9 7/8"  
 BIT BOX CONN. 4 1/2 REG.  
 ADJUSTABLE TORQUE 20,000 ft-lb  
 REV / GAL AT FULL LOAD 0.22  
 REV / GAL AT NO LOAD 0.28

DIFF. PRES. 1010 psi

6 1/2" - 6 3/4" 6 - 7 8.1 Stg

**MUD LUBE**  
 BIT TO BEND FIXED 56"  
 BIT TO BEND ADJ. 48"  
 MAX W.O.B. 90,000 lb.  
 O/A LENGTH 356.8'  
 MAX. OVERPULL AND RERUN 406,403 lb.  
 ABSOLUTE OVERPULL 780,000 lb.  
 TOOL SHIPMENT WEIGHT 2460 lb.

**SEALED BEARING**  
 BIT TO BEND FIXED 65.5"  
 BIT TO BEND ADJ. 77.4"  
 MAX W.O.B. 156,000 lb.  
 O/A LENGTH 364.4'  
 MAX. OVERPULL AND RERUN 479,000 lb.  
 ABSOLUTE OVERPULL 650,000 lb.  
 TOOL SHIPMENT WEIGHT 2536 lb.

**HOLE SIZE** 7 7/8" - 9 7/8"  
 BIT BOX CONN. 4 1/2 REG.  
 ADJUSTABLE TORQUE 10,000 ft-lb  
 REV/GAL AT FULL LOAD 0.33  
 REV/GAL AT NO LOAD 0.40

**DIFF. PRES. HARD** 1820 psi

**HARD RUBBER**

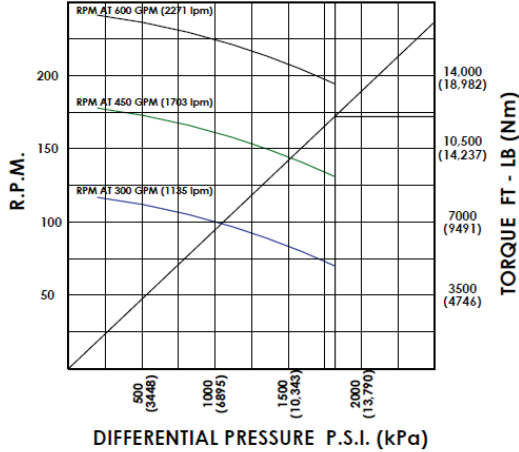

VOLUME (gpm)	300-600
SPEED (rpm)	70-240
TORQUE AT FULL LOAD (ft-lb)	12,040
OUTPUT AT FULL LOAD (hp)	447

6 1/2 - 6 3/4 6-7 8.1 Stg.

**STANDARD RUBBER**

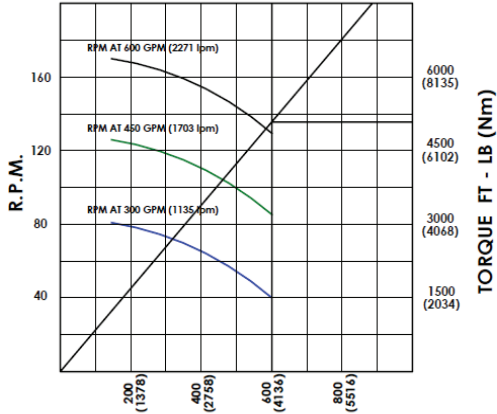

**DIFFERENTIAL PRESSURE P.S.I. (kPa)**

VOLUME (gpm)	300-600
SPEED (rpm)	40-170
TORQUE AT FULL LOAD (ft-lb)	5070
OUTPUT AT FULL LOAD (hp)	125.7

**6 1/2" - 6 3/4" 9 - 10 4.0 Stg**

**MUD LUBE**  
 BIT TO BEND FIXED 56"  
 BIT TO BEND ADJ. 48"  
 MAX W.O.B. 90,000 lb.  
 O/A LENGTH 284.8"  
 MAX. OVERPULL AND RERUN 406,403 lb.  
 ABSOLUTE OVERPULL 780,000 lb.  
 TOOL SHIPMENT WEIGHT 2326 lb.

**SEALED BEARING**  
 BIT TO BEND FIXED 65.5"  
 BIT TO BEND ADJ. 77.4"  
 MAX W.O.B. 156,000 lb.  
 O/A LENGTH 290.4"  
 MAX. OVERPULL AND RERUN 479,000 lb.  
 ABSOLUTE OVERPULL 650,000 lb.  
 TOOL SHIPMENT WEIGHT 2432.6 lb.

**HOLE SIZE** 7 7/8" - 9 7/8"  
 BIT BOX CONN. 3 1/2 REG.  
 ADJUSTABLE TORQUE 10,000 ft-lb  
 REV/GAL AT FULL LOAD 0.21  
 REV/GAL AT NO LOAD 0.28

**DIFF. PRES. STANDARD** 600 psi  
**DIFF. PRES. HARD** 900 psi

**HARD RUBBER**

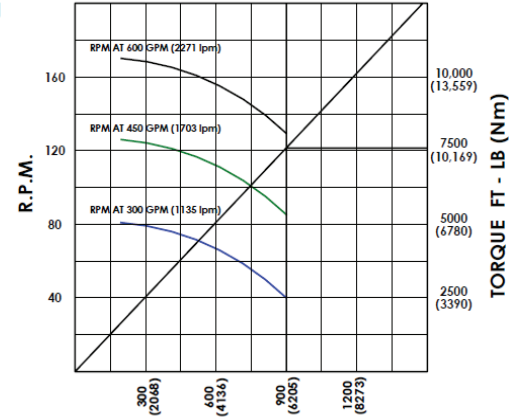

**DIFFERENTIAL PRESSURE P.S.I. (kPa)**

VOLUME (gpm)	300-600
SPEED (rpm)	40-170
TORQUE AT FULL LOAD (ft-lb)	7610
OUTPUT AT FULL LOAD (hp)	188.6

**6 1/2" - 6 3/4" 9-10 4.0 Stg.**

### STANDARD RUBBER

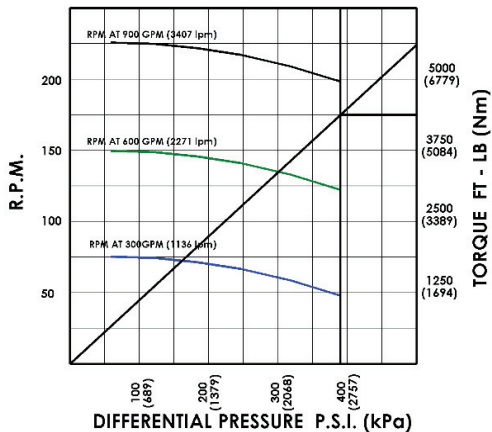

VOLUME (gpm)	300 - 900
SPEED (rpm)	48 - 226
TORQUE AT FULL LOAD (ft-lb)	4377
OUTPUT AT FULL LOAD (hp)	165.2

### 8.00" 4-5 3.6 Stg

**MUD LUBE**  
 BIT TO BEND FIXED 66.5"  
 BIT TO BEND ADJ. 80.2"  
 MAX W.O.B. 140,000 lb.  
 O/A LENGTH 303.5"  
 MAX. OVERPULL AND RERUN 610,700 lb.  
 ABSOLUTE OVERPULL 1,100,000 lb.  
 TOOL SHIPPING WEIGHT 3107 lb.

**SEALED BEARING**  
 BIT TO BEND FIXED 89.5"  
 BIT TO BEND ADJ. 78.5"  
 MAX W.O.B. 210,000 lb.  
 O/A LENGTH 312.3"  
 MAX. OVERPULL AND RERUN 679,000 lb.  
 ABSOLUTE OVERPULL 990,000 lb.  
 TOOL SHIPPING WEIGHT 3245.4 lb.

**HOLE SIZE** 9 7/8" - 12 1/4"  
 BIT BOX CONN. 6 5/8 REG.  
 ADJUSTABLE TORQUE 40,000 ft-lb.  
 REV/GAL AT FULL LOAD 0.22  
 REV/GAL AT NO LOAD 0.25

DIFF. PRES. STANDARD 390 psi  
 DIFF. PRES. HARD 488 psi

### HARD RUBBER

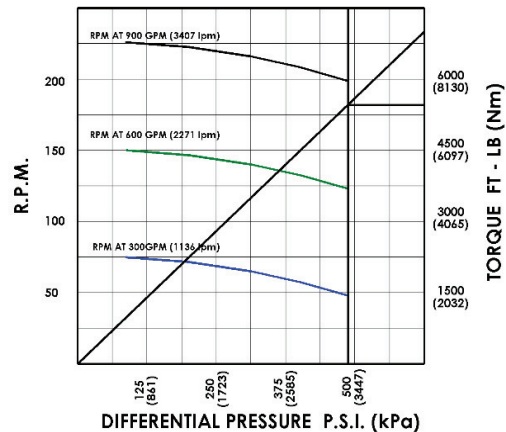

VOLUME (gpm)	300 - 900
SPEED (rpm)	48 - 226
TORQUE AT FULL LOAD (ft-lb)	5471
OUTPUT AT FULL LOAD (hp)	206.6

8.00 4-5 3.6 Stg.

# 8.00" 5 - 6 5.2 Stg EW

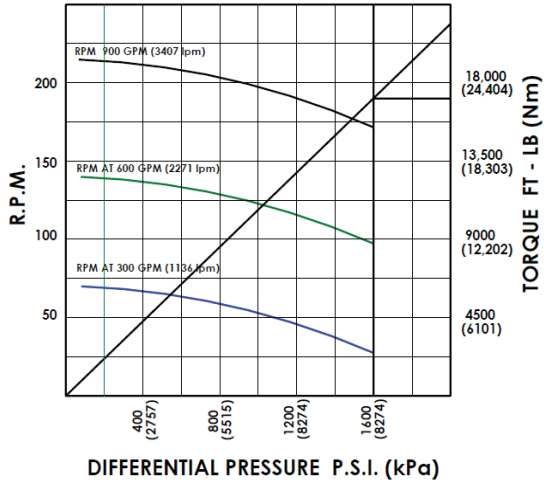

VOLUME (gpm)	300-900
SPEED (rpm)	30-215
TORQUE AT FULL LOAD (ft-lb)	17120
OUTPUT AT FULL LOAD (hp)	522.4

- MUD LUBE**
- BIT TO BEND FIXED 66.5"
  - BIT TO BEND ADJ. 80.2"
  - MAX W.O.B. 140,000 lb.
  - O/A LENGTH 383.5"
  - MAX. OVERPULL AND RERUN 610,700 lb.
  - ABSOLUTE OVERPULL 1,100,000 lb.
  - TOOL SHIPPING WEIGHT 4200.8 lb.
- SEALED BEARING**
- BIT TO BEND FIXED 76.5"
  - BIT TO BEND ADJ. 89.5"
  - MAX W.O.B. 210,000
  - O/A LENGTH 397"
  - MAX. OVERPULL AND RERUN 679,000
  - ABSOLUTE OVERPULL 990,000
  - TOOL SHIPPING WEIGHT 4369 lb.
- HOLE SIZE**
- BIT BOX CONN. 9 7/8" - 12 1/4"
  - ADJUSTABLE TORQUE 6 5/8 REG.
  - REV/GAL AT FULL LOAD 40,000 ft-lb
  - REV/GAL AT NO LOAD 0.17
  - DIFF. PRES. HARD 0.23
  - 1600psi

8.00 4-5 3.6 Stg.

**STANDARD RUBBER**

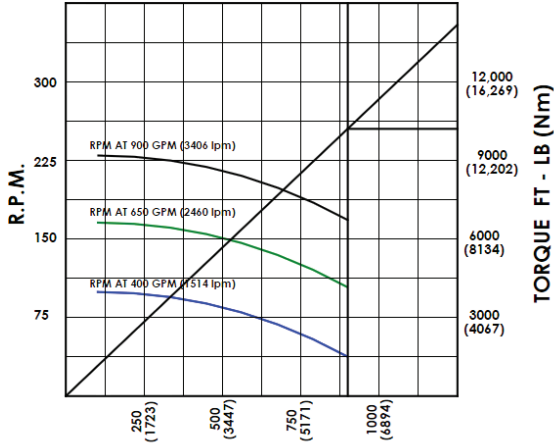

**DIFFERENTIAL PRESSURE P.S.I. (kPa)**

VOLUME (gpm)	400-900
SPEED (rpm)	40-230
TORQUE AT FULL LOAD (ft-lb)	10200
OUTPUT AT FULL LOAD (hp)	326.8

**8.00" 5 - 6 6 Stg**

**MUD LUBE**  
 BIT TO BEND FIXED 66.6"  
 BIT TO BEND ADJUSTABLE 80.2"  
 MAX W.O.B. 140,000 lb.  
 O/A LENGTH 377"  
 MAX. OVERPULL AND RERUN 610,700 lb.  
 ABSOLUTE OVERPULL 1,100,000 lb.  
 TOOL SHIPPING WEIGHT 3780 lb.

**SEALED BEARING**  
 BIT TO BEND FIXED 76.5"  
 BIT TO BEND ADJUSTABLE 89.5"  
 MAX W.O.B. 210,000 lb.  
 O/A LENGTH 391"  
 MAX OVERPULL AND RERUN 679,000 lb.  
 ABSOLUTE OVERPULL 990,000 lb.  
 TOOL SHIPPING WEIGHT 3949 lb.

**HOLE SIZE** 9 7/8" - 12 1/4"  
 BIT BOX CONN. 6 5/8 REG.  
 ADJUSTABLE TORQUE 40,000 ft-lb  
 REV/GAL AT FULL LOAD 0.18  
 REV/ GAL AT NO LOAD 0.25

DIFF. PRES. 900 psi

**8.00 5-6 6 Stg.**



**STANDARD RUBBER**

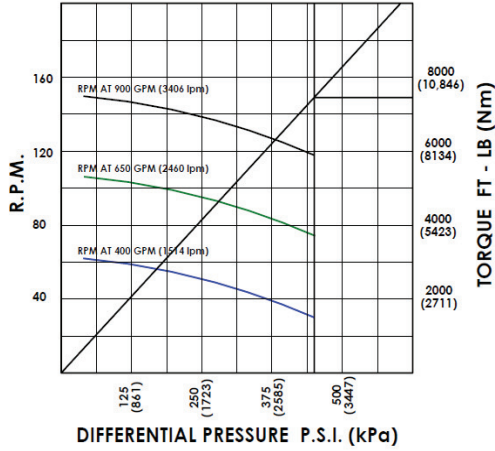

VOLUME (gpm)	400-900
SPEED (rpm)	30-150
TORQUE AT FULL LOAD (ft-lb)	7470
OUTPUT AT FULL LOAD (hp)	168.1

**8.00" 7 - 8 3 Stg**

**MUD LUBE**  
 BIT TO BEND FIXED 66.5"  
 BIT TO BEND ADJ. 80.2"  
 MAX W.O.B. 140,000 lb.  
 O/A LENGTH 303"  
 MAX. OVERPULL AND RERUN 610,700 lb.  
 ABSOLUTE OVERPULL 1,100,000 lb.  
 TOOL SHIPPING WEIGHT 3360.8 lb.

**SEALED BEARING**  
 BIT TO BEND FIXED 76.5"  
 BIT TO BEND ADJ. 89.5"  
 MAX W.O.B. 210,000 lb.  
 O/A LENGTH 317"  
 MAX. OVERPULL AND RERUN 679,000 lb.  
 ABSOLUTE OVERPULL 990,000 lb.  
 TOOL SHIPPING WEIGHT 3529 lb.

**HOLE SIZE**  
 BIT BOX CONN. 9 7/8" - 12 1/4"  
 ADJUSTABLE TORQUE 6 5/8 REG.  
 REV/GAL AT FULL LOAD 40,000 ft-lb  
 REV/GAL AT NO LOAD 0.13  
 0.16

**DIFF. PRES. STANDARD** 450 psi  
**DIFF. PRES. HARD RUBBER** 680 psi

**HARD RUBBER**

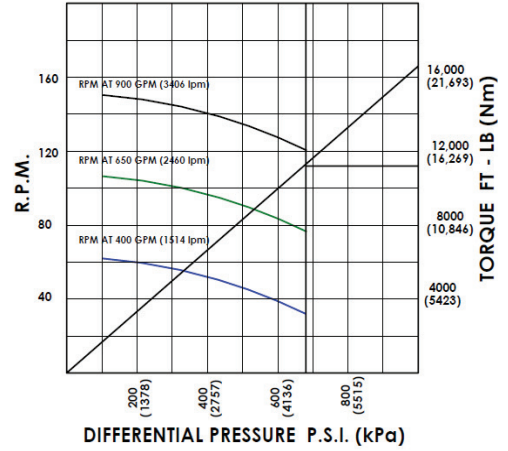

VOLUME (gpm)	400-900
SPEED (rpm)	30-150
TORQUE AT FULL LOAD (ft-lb)	11200
OUTPUT AT FULL LOAD (hp)	252

**8.00**  
**7-8 3 Stg.**

**STANDARD RUBBER**

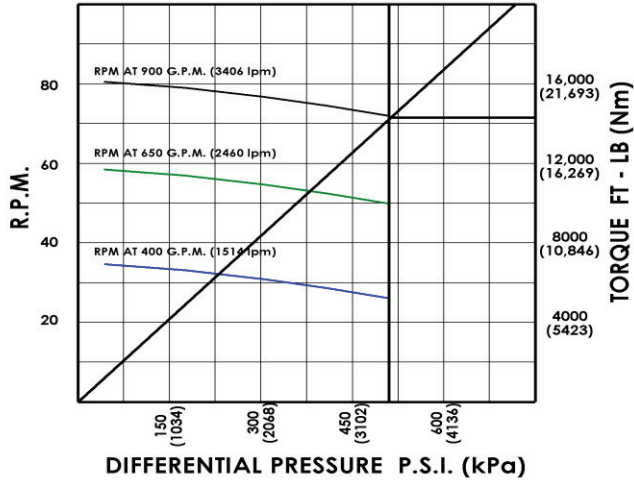

**DIFFERENTIAL PRESSURE P.S.I. (kPa)**

VOLUME (gpm)	400-900
SPEED (rpm)	27-81
TORQUE AT FULL LOAD (ft-lb)	14,300
OUTPUT AT FULL LOAD (hp)	199.1

**8.00" 7 - 8 3.4 Stg**

<b>MUD LUBE</b>	
BIT TO BEND FIXED	66.5 "
BIT TO BEND ADJ.	80.2 "
MAX W.O.B.	140,000 lb.
O/A LENGTH	443.5"
MAX. OVERPULL AND RERUN	610,700 lb.
ABSOLUTE OVERPULL	1,100,000 lb.
TOOL SHIPPING WEIGHT	4541.8 lb.
<b>SEALED BEARING</b>	
BIT TO BEND FIXED	76.5"
BIT TO BEND ADJ.	89.5"
MAX W.O.B.	210,000 lb.
O/A LENGTH	457 "
MAX OVERPULL AND RERUN	679,000 lb.
ABSOLUTE OVERPULL	990,000 lb.
TOOL SHIPPING WEIGHT	4791 lb.
<b>HOLE SIZE</b>	
BIT BOX CONN.	9 7/8" - 12 1/4"
ADJUSTABLE TORQUE	6 5/8 REG.
REV/GAL AT FULL LOAD	40,000 ft-lb
REV/GAL AT NO LOAD	0.08
DIFF. PRES.	510 psi

**8.00 7-8 3.4 Stg.**

**STANDARD RUBBER**

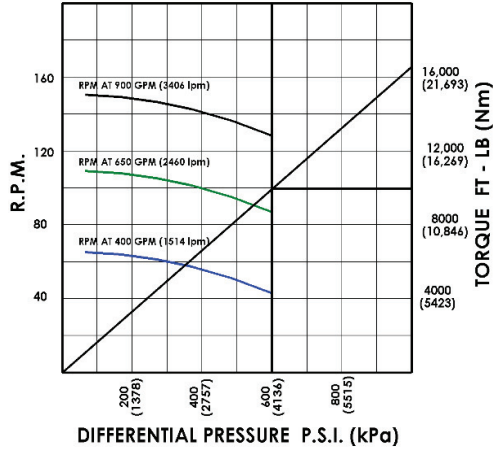

VOLUME (gpm)	400-900
SPEED (rpm)	45-150
TORQUE AT FULL LOAD (ft-lb)	9950
OUTPUT AT FULL LOAD (hp)	244.8

**8.00" 7 - 8 4 Stg**

**MUD LUBE**  
 BIT TO BEND FIXED 66.5"  
 BIT TO BEND ADJ. 80.2"  
 MAX W.O.B. 140,000 lb.  
 O/A LENGTH 346.2"  
 MAX. OVERPULL AND RERUN 610,700 lb.  
 ABSOLUTE OVERPULL 1,100,000 lb.  
 TOOL SHIPPING WEIGHT 3826 lb.

**SEALED BEARING**  
 BIT TO BEND FIXED 76.5"  
 BIT TO BEND ADJ. 89.5"  
 MAX W.O.B. 210,000 lb.  
 O/A LENGTH 360"  
 MAX. OVERPULL AND RERUN 679,000 lb.  
 ABSOLUTE OVERPULL 990,000 lb.  
 TOOL SHIPPING WEIGHT 3995 lb.

**HOLE SIZE**  
 BIT BOX CONN. 9 7/8" - 12 1/4"  
 ADJUSTABLE TORQUE 6 5/8 REG.  
 REV/GAL AT FULL LOAD 40,000 ft-lb  
 REV/GAL AT NO LOAD 0.14

**DIFF. PRES. STANDARD** 600 psi  
**DIFF. PRES. HARD RUBBER** 900 psi

**HARD RUBBER**

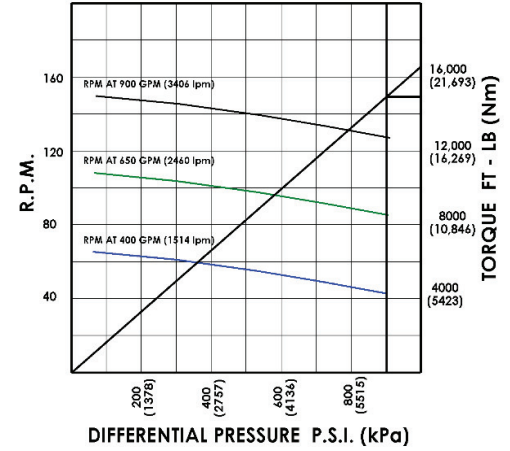

VOLUME (gpm)	400-900
SPEED (rpm)	45-150
TORQUE AT FULL LOAD (ft-lb)	14930
OUTPUT AT FULL LOAD (hp)	367.3

**8.00 7-8 4 Stg.**

**STANDARD RUBBER**

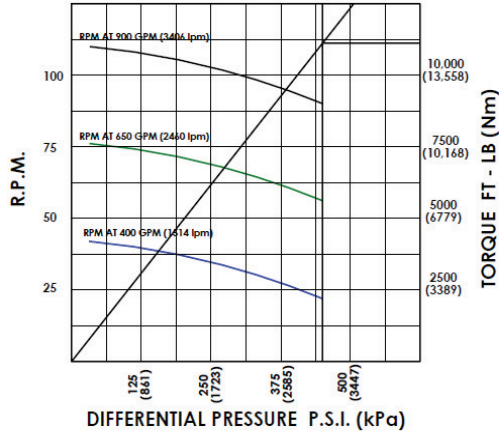

VOLUME (gpm)	400-900
SPEED (rpm)	22-110
TORQUE AT FULL LOAD (ft-lb)	11050
OUTPUT AT FULL LOAD (hp)	189.6

**8.00" 9-10 3 Stg**

**MUD LUBE**  
 BIT TO BEND FIXED 44.5"  
 BIT TO BEND ADJ. 80.2"  
 MAX W.O.B. 140,000 lb.  
 O/A LENGTH 377.5"  
 MAX. OVERPULL AND RERUN 610,000 lb.  
 ABSOLUTE OVERPULL 1,100,000 lb.  
 TOOL SHIPPING WEIGHT 4075.8 lb.

**SEALED BEARING**  
 BIT TO BEND FIXED 76.5"  
 BIT TO BEND ADJ. 89.5"  
 MAX W.O.B. 210,000 lb.  
 O/A LENGTH 391"  
 MAX. OVERPULL AND RERUN 679,000 lb.  
 ABSOLUTE OVERPULL 990,000 lb.  
 TOOL SHIPPING WEIGHT 4244 lb.

**HOLE SIZE** 9 7/8" - 12 1/4"  
**BIT BOX CONN.** 6 5/8 REG.  
**ADJUSTABLE TORQUE** 40,000 ft-lb  
**REV/GAL AT FULL LOAD** 0.10  
**REV/GAL AT NO LOAD** 0.12

**DIFF. PRES. STANDARD** 450 psi  
**DIFF. PRES. HARD** 680 psi

**HARD RUBBER**

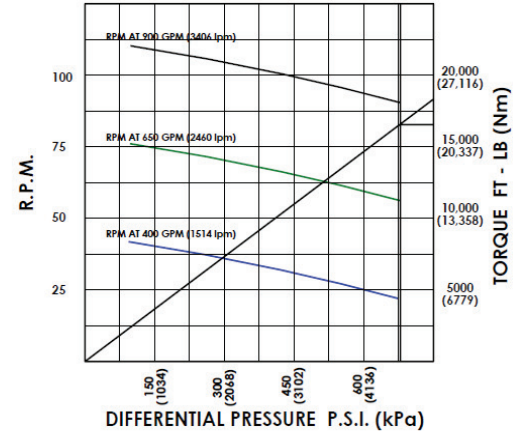

VOLUME (gpm)	400-900
SPEED (rpm)	22-110
TORQUE AT FULL LOAD (ft-lb)	16580
OUTPUT AT FULL LOAD (hp)	284.6

**8.00 9-10 3 Stg.**

### STANDARD RUBBER

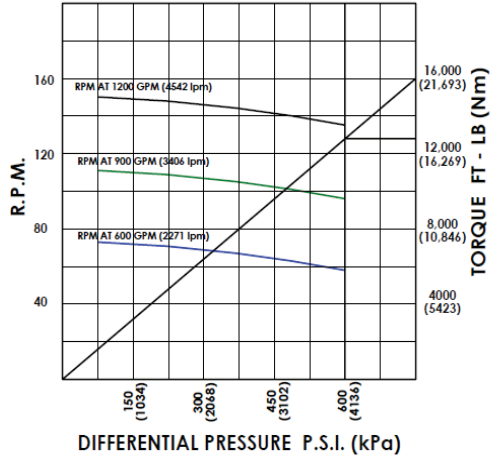

DIFFERENTIAL PRESSURE P.S.I. (kPa)

VOLUME (gpm)	600-1200
SPEED (rpm)	58-150
TORQUE AT FULL LOAD (ft-lb)	12820
OUTPUT AT FULL LOAD (hp)	330

### 9 5/8" 5 - 6 4 Stg

MUD LUBE  
 BIT TO BEND FIXED 78.1 "  
 BIT TO BEND ADJ. 92.7 "  
 MAX. W.O.B. 165,000 lb.  
 O/A LENGTH 388.9'  
 MAX. OVERPULL AND RERUN 165,000 lb.  
 ABSOLUTE OVERPULL 1,250,000 lb.  
 TOOL SHIPPING WEIGHT 5983.2 lb.

HOLE SIZE 12 1/4" - 17 1/2"  
 BIT BOX CONN. 7 5/8 REG.  
 ADJUSTABLE TORQUE 75,000 ft-lb  
 REV/GAL AT FULL LOAD 0.112  
 REV/GAL AT NO LOAD 0.125

DIFF. PRES. STANDARD 600 psi  
 DIFF. PRES. HARD RUBBER 900 psi

### HARD RUBBER

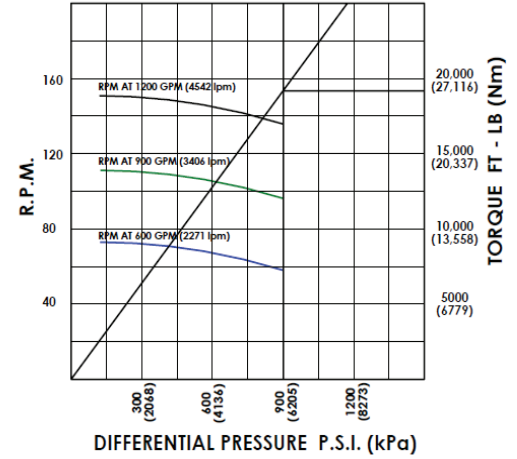

DIFFERENTIAL PRESSURE P.S.I. (kPa)

VOLUME (gpm)	600-1200
SPEED (rpm)	58-150
TORQUE AT FULL LOAD (ft-lb)	19240
OUTPUT AT FULL LOAD (hp)	495.3

9 5/8 5-6 4 Stg.

**STANDARD RUBBER**

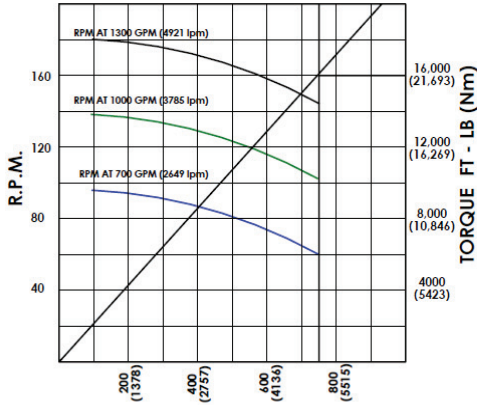

DIFFERENTIAL PRESSURE P.S.I. (kPa)

VOLUME (gpm)	700-1300
SPEED (rpm)	60-180
TORQUE AT FULL LOAD (ft-lb)	16120
OUTPUT AT FULL LOAD (hp)	442.7

**9 5/8" 5 - 6 5 Stg**

**MUD LUBE**  
 BIT TO BEND FIXED 78.1"  
 BIT TO BEND ADJ. 92.7"  
 MAX W.O.B. 145,000 lb.  
 O/A LENGTH 390.9"  
 MAX. OVERPULL AND RERUN 145,000 lb.  
 ABSOLUTE OVERPULL 1,250,000 lb.  
 TOOL SHIPPING WEIGHT 6122.2 lb.

**HOLE SIZE** 12 1/4"- 17 1/2"  
 BIT BOX CONN. 7 5/8 REG.  
 ADJUSTABLE TORQUE 75,000 ft-lb  
 REV/GAL AT FULL LOAD 0.11  
 REV/GAL AT NO LOAD 0.13

DIFF. PRES. STANDARD 750 psi  
 DIFF. PRES. HARD RUBBER 1130 psi

**HARD RUBBER**

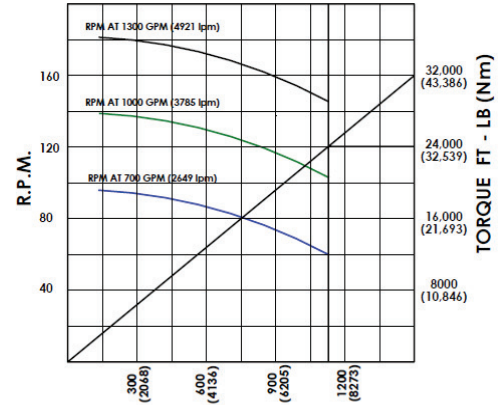

DIFFERENTIAL PRESSURE P.S.I. (kPa)

VOLUME (gpm)	700-1300
SPEED (rpm)	60-180
TORQUE AT FULL LOAD (ft-lb)	24170
OUTPUT AT FULL LOAD (hp)	668.4

# 9 5/8" 6 - 7 3.5 Stg EW

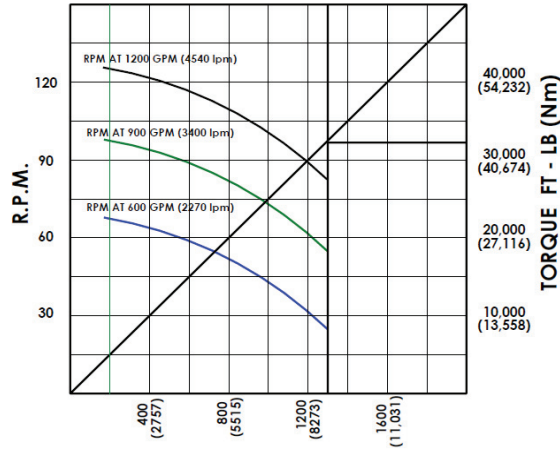

DIFFERENTIAL PRESSURE P.S.I. (kPa)

VOLUME (gpm)	600-1200
SPEED (rpm)	25-125
TORQUE AT FULL LOAD (ft-lb)	32275
OUTPUT AT FULL LOAD (hp)	507.8

MUD LUBE	
BIT TO BEND FIXED	78.1"
BIT TO BEND ADJ.	92.7"
MAX W.O.B.	165,000 lb.
O/A LENGTH	368.9
MAX. OVERPULL AND RERUN	165,000 lb.
ABSOLUTE OVERPULL	1,250,000 lb.
TOOL SHIPPING WEIGHT	6290.2 lb.
HOLE SIZE	
BIT BOX CONN.	12 1/4" - 17 1/2"
ADJUSTABLE TORQUE	7 5/8 REG.
REV/GAL AT FULL LOAD	75,000 ft-lb
REV/GAL AT NO LOAD	0.068
	0.104
DIFF. PRES.	1300 psi

9 5/8 6-7 3.5 Stg.

### STANDARD RUBBER

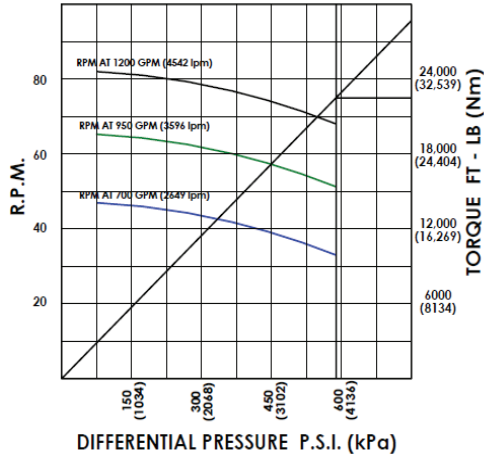

DIFFERENTIAL PRESSURE P.S.I. (kPa)

VOLUME (gpm)	700-1200
SPEED (rpm)	33-82
TORQUE AT FULL LOAD (ft-lb)	22500
OUTPUT AT FULL LOAD (hp)	291

### 9 5/8" 7 - 8 3.9 Stg

MUD LUBE  
 BIT TO BEND FIXED  
 BIT TO BEND ADJ.  
 MAX W. O. B.  
 O/A LENGTH  
 MAX. OVERPULL AND RERUN  
 ABSOLUTE OVERPULL  
 TOOL SHIPPING WEIGHT

78.1"  
 92.7"  
 165,000 lb.  
 458.9"  
 145,000 lb.  
 1,250,000 lb.  
 7279.2 lb.

HOLE SIZE  
 BIT BOX CONN.  
 ADJUSTABLE TORQUE  
 REV/GAL AT FULL LOAD  
 REV/GAL AT NO LOAD

12 1/4" - 17 1/2"  
 7 5/8 REG.  
 75,000 ft-lb  
 0.056  
 0.068

DIFF. PRES. STANDARD  
 DIFF. PRES. HARD RUBBER

590 psi  
 880 psi

### HARD RUBBER

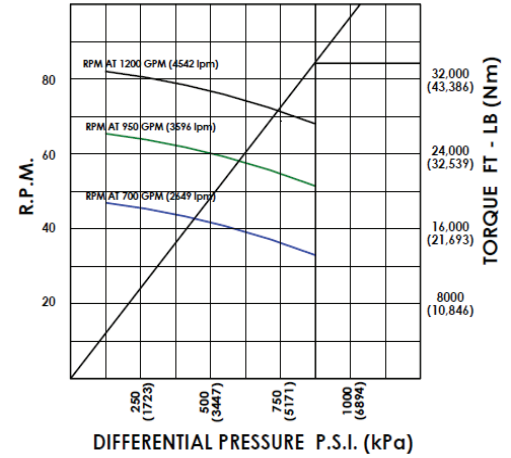

DIFFERENTIAL PRESSURE P.S.I. (kPa)

VOLUME (gpm)	700-1200
SPEED (rpm)	33-82
TORQUE AT FULL LOAD (ft-lb)	33750
OUTPUT AT FULL LOAD (hp)	437.7



**STANDARD RUBBER**

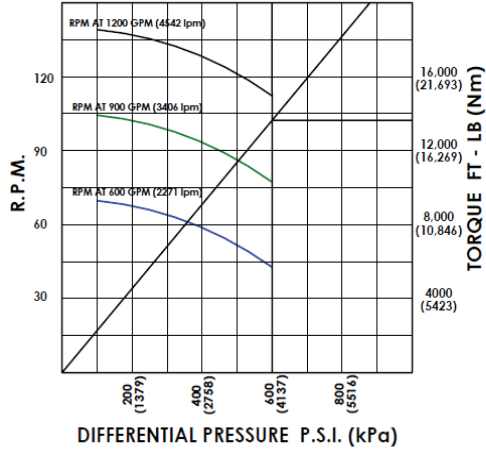

VOLUME (gpm)	600-1200
SPEED (rpm)	43-139
TORQUE AT FULL LOAD (ft-lb)	13,654
OUTPUT AT FULL LOAD (hp)	291.6

**9 5/8" 7 - 8 4.8 Stg**

MUD LUBE  
 BIT TO BEND FIXED 78.1"  
 BIT TO BEND ADJ. 92.7"  
 MAX W.O.B. 145,000 lb.  
 O/A LENGTH 405.4"  
 MAX. OVERPULL AND RERUN 145,000 lb.  
 ABSOLUTE OVERPULL 1,250,000 lb.  
 TOOL SHIPPING WEIGHT 6661.2 lb.

HOLE SIZE 12 1/4" - 17 1/2"  
 BIT BOX CONN. 6 5/8 REG., 7 5/8 REG.  
 ADJUSTABLE TORQUE 75,000 ft-lb  
 REV/GAL AT FULL LOAD 0.09  
 REV/GAL AT NO LOAD 0.11

DIFF. PRES. STANDARD 601 psi  
 DIFF. PRES. HARD RUBBER 751 psi

**HARD RUBBER**

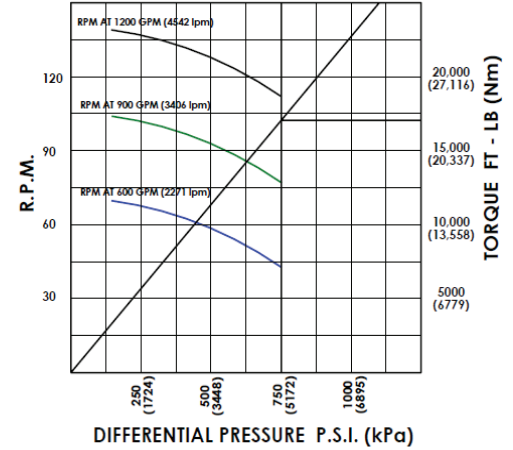

VOLUME (gpm)	600-1200
SPEED (rpm)	43-139
TORQUE AT FULL LOAD (ft-lb)	17,067
OUTPUT AT FULL LOAD (hp)	364.5

**9 5/8 7-8 4.8 Stg.**

**STANDARD RUBBER**

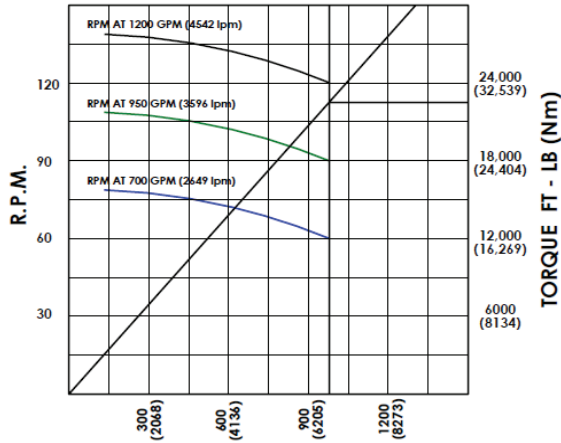

DIFFERENTIAL PRESSURE P.S.I. (kPa)

VOLUME (gpm)	700-1200
SPEED (rpm)	60-140
TORQUE AT FULL LOAD (ft-lb)	22500
OUTPUT AT FULL LOAD (hp)	515

**9 5/8" 7 - 8 6.5 Stg**

MUD LUBE  
 BIT TO BEND FIXED 78.1"  
 BIT TO BEND ADJ. 92.7"  
 MAX W.O.B. 165,000 lb.  
 O/A LENGTH 459"  
 MAX. OVERPULL AND RERUN 165,000 lb.  
 ABSOLUTE OVERPULL 1,250,000 lb.  
 TOOL SHIPPING WEIGHT 7279.2 lb.

HOLE SIZE 12 1/4" - 17 1/2"  
 BIT BOX CONN. 4 5/8 REG, 7 5/8 REG.  
 ADJUSTABLE TORQUE 75,000 ft-lb  
 REV/GAL AT FULL LOAD 0.10  
 REV/GAL AT NO LOAD 0.11

DIFF. PRES. 980 psi

**9 5/8 7-8 6.5 Stg.**

**STANDARD RUBBER**

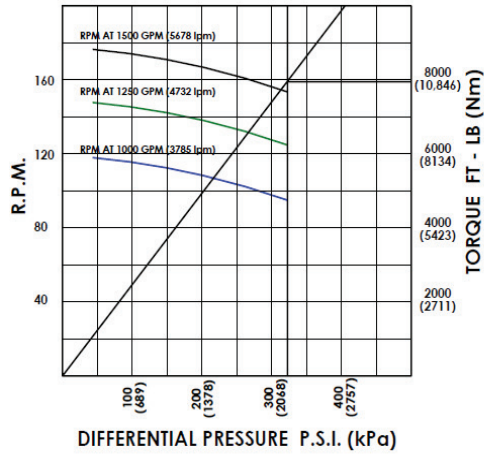

DIFFERENTIAL PRESSURE P.S.I. (kPa)

VOLUME (gpm)	1000-1500
SPEED (rpm)	95-176
TORQUE AT FULL LOAD (ft-lb)	7954
OUTPUT AT FULL LOAD (hp)	232.1

**11 1/4" 3 - 4 3.6 Stg**

**MUD LUBE**  
 BIT TO BEND FIXED 79.4"  
 BIT TO BEND ADJ. 94.2"  
 MAX W.O.B. 153,300 lb.  
 O/A LENGTH 349.4"  
 MAX. OVERPULL AND RERUN 844,470 lb.  
 ABSOLUTE OVERPULL 2,019,433 lb.  
 TOOL SHIPPING WEIGHT 7223 lb.

**SEALED BEARING**  
 BIT TO BEND FIXED 87.2"  
 BIT TO BEND ADJ. 102.1"  
 MAX W.O.B. 240,000 lb.  
 O/A LENGTH 377.2"  
 MAX. OVERPULL AND RERUN 840,000 lb.  
 ABSOLUTE OVERPULL 1,510,000 lb.  
 TOOL SHIPPING WEIGHT 7528.8 lb.

**HOLE SIZE** 14 3/4" - 17 1/2"  
 BIT BOX CONN. 7 5/8 REG.  
 ADJUSTABLE TORQUE 80,000 ft-lb  
 REV/GAL AT FULL LOAD 0.102  
 REV/GAL AT NO LOAD 0.117

DIFF. PRES. STANDARD 323 psi  
 DIFF. PRES. HARD RUBBER 404 psi

**HARD RUBBER**

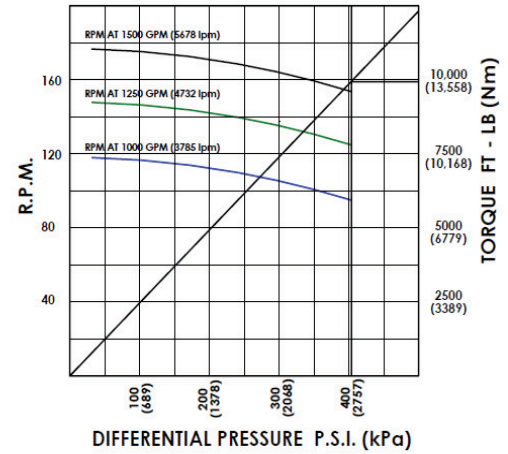

DIFFERENTIAL PRESSURE P.S.I. (kPa)

VOLUME (gpm)	1000-1500
SPEED (rpm)	95-176
TORQUE AT FULL LOAD (ft-lb)	9943
OUTPUT AT FULL LOAD (hp)	290.1

**11 1/4 3-4 3.6 Stg.**

### STANDARD RUBBER

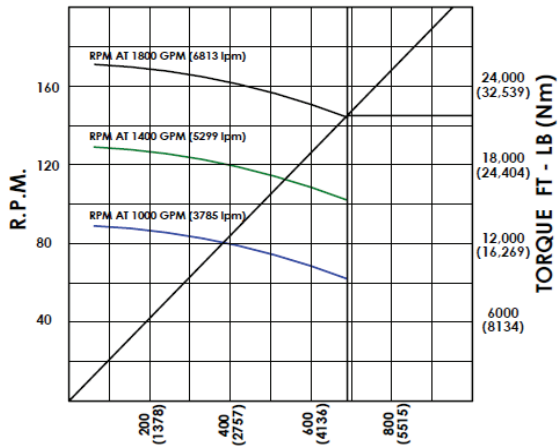

DIFFERENTIAL PRESSURE P.S.I. (kPa)

VOLUME (gpm)	1000-1800
SPEED (rpm)	62-170
TORQUE AT FULL LOAD (ft-lb)	21800
OUTPUT AT FULL LOAD (hp)	602.8

### 11 1/4" 5-6 4.6 Stg

**MUD LUBE**  
 BIT TO BEND FIXED 79.4"  
 BIT TO BEND ADJ. 94.2"  
 MAX W.O.B. 153,300 lb.  
 O/A LENGTH 398.4"  
 MAX. OVERPULL AND RERUN 844,000 lb.  
 ABSOLUTE OVERPULL 2,019,633 lb.  
 TOOL SHIPPING WEIGHT 8062 lb.

**SEALED BEARING**  
 BIT TO BEND FIXED 87.2"  
 BIT TO BEND ADJ. 102.1"  
 MAX W.O.B. 240,000 lb.  
 O/A LENGTH 406.2"  
 MAX. OVERPULL AND RERUN 840,000 lb.  
 ABSOLUTE OVERPULL 1,510,000 lb.  
 TOOL SHIPPING WEIGHT 8367.9 lb.

**HOLE SIZE** 14 3/4" - 17 1/2"  
 BIT BOX CONN. 7 5/8 REG.  
 ADJUSTABLE TORQUE 80,000 ft-lb  
 REV/GAL AT FULL LOAD 0.080  
 REV/GAL AT NO LOAD 0.094

DIFF. PRES. 690 psi

11 1/4 5-6 4.6 Stg.

## 11 1/4" 6 - 7 3.5 Stg EW

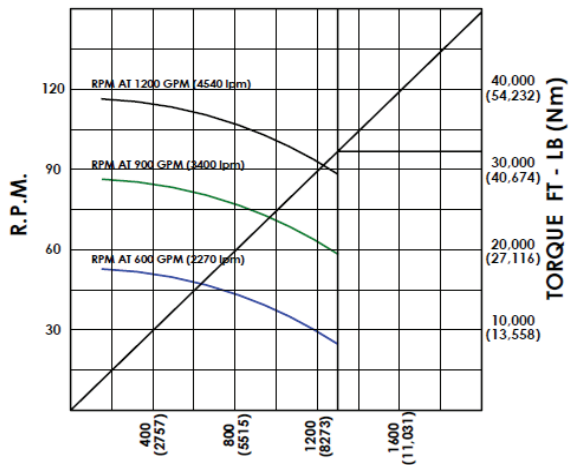

### DIFFERENTIAL PRESSURE P.S.I. (kPa)

VOLUME (gpm)	600-1200
SPEED (rpm)	25-125
TORQUE AT FULL LOAD (ft-lb)	32275
OUTPUT AT FULL LOAD (hp)	541.7

**MUD LUBE**  
 BIT TO BEND FIXED 79.4"  
 BIT TO BEND ADJ. 94.2"  
 MAX W.O.B. 153,300 lb.  
 O/A LENGTH 398.4"  
 MAX. OVERPULL AND RERUN 844,470 lb.  
 ABSOLUTE OVERPULL 2,019,633 lb.  
 TOOL SHIPPING WEIGHT 8062 lb.

**SEALED BEARING**  
 BIT TO BEND FIXED 87.2"  
 BIT TO BEND ADJ. 102.1"  
 MAX W.O.B. 240,000 lb.  
 O/A LENGTH 406.2"  
 MAX. OVERPULL AND RERUN 840,000 lb.  
 ABSOLUTE OVERPULL 1,510,000 lb.  
 TOOL SHIPPING WEIGHT 8367.9 lb.

**HOLE SIZE** 14 3/4" - 17 1/2"  
 BIT BOX CONN. 7 5/8 REG.  
 ADJUSTABLE TORQUE 80,000 ft-lb  
 REV/GAL AT FULL LOAD 0.073  
 REV/GAL AT NO LOAD 0.104

DIFF. PRES. 1300 psi

### STANDARD RUBBER

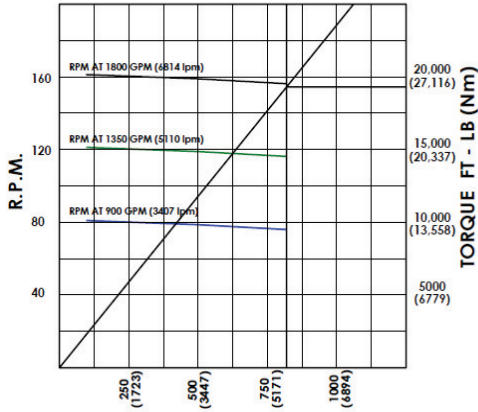

DIFFERENTIAL PRESSURE P.S.I. (kPa)

VOLUME (gpm)	900-1800
SPEED (rpm)	76-162
TORQUE AT FULL LOAD (ft-lb)	19,369
OUTPUT AT FULL LOAD (hp)	576.2

### 1 1/4" 6 - 7 5.5 Stg

**MUD LUBE**  
 BIT TO BEND FIXED 79.4"  
 BIT TO BEND ADJ. 94.2"  
 MAX W.O.B. 153,300 lb.  
 O/A LENGTH 418.5'  
 MAX. OVERPULL AND RERUN 844,470 lb.  
 ABSOLUTE OVERPULL 2,019,633 lb.  
 TOOL SHIPPING WEIGHT 8932 lb.

**SEALED BEARING**  
 BIT TO BEND FIXED 87.2"  
 BIT TO BEND ADJ. 102.1"  
 MAX W.O.B. 240,000 lb.  
 O/A LENGTH 426.1"  
 MAX. OVERPULL AND RERUN 840,000 lb.  
 ABSOLUTE OVERPULL 1,510,000 lb.  
 TOOL SHIPPING WEIGHT 9191 lb.

**HOLE SIZE** 14 3/4" - 17 1/2"  
 BIT BOX CONN. 7 5/8 REG.  
 ADJUSTABLE TORQUE 80,000 ft-lb  
 REV/GAL AT FULL LOAD 0.086  
 REV/GAL AT NO LOAD 0.089

**DIFF. PRES. STANDARD** 820 psi  
**DIFF. PRES. HARD RUBBER** 1230 psi

### HARD RUBBER

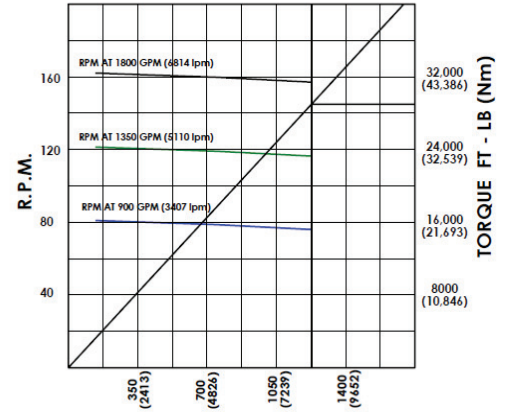

DIFFERENTIAL PRESSURE P.S.I. (kPa)

VOLUME (gpm)	900-1800
SPEED (rpm)	76-162
TORQUE AT FULL LOAD (ft-lb)	29,053
OUTPUT AT FULL LOAD (hp)	864.4

1 1/4 6-7 5.5 Stg.

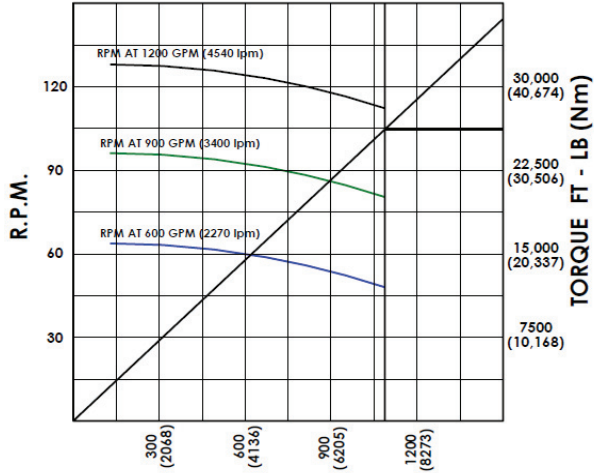

### DIFFERENTIAL PRESSURE P.S.I. (kPa)

VOLUME (gpm)	600-1200
SPEED (rpm)	48-128
TORQUE AT FULL LOAD (ft-lb)	26160
OUTPUT AT FULL LOAD (hp)	558.8

## 11 1/4" 7 - 8 4.8 Stg EW

**MUD LUBE**  
 BIT TO BEND FIXED 79.4"  
 BIT TO BEND ADJ. 94.2"  
 MAX W.O.B. 153,300 lb.  
 O/A LENGTH 419.8"  
 MAX. OVERPULL AND RERUN 844,470 lb.  
 ABSOLUTE OVERPULL 2,019,633 lb.  
 TOOL SHIPPING WEIGHT 7710 lb.

**SEALED BEARING**  
 BIT TO BEND FIXED 87.2"  
 BIT TO BEND ADJ. 102.1"  
 MAX W.O.B. 240,000 lb.  
 O/A LENGTH 427.6"  
 MAX. OVERPULL AND RERUN 840,000 lb.  
 ABSOLUTE OVERPULL 1,510,000 lb.  
 TOOL SHIPPING WEIGHT 7969 lb.

**HOLE SIZE** 14 3/4" - 17 1/2"  
**BIT BOX CONN.** 7 5/8 REG.  
**ADJUSTABLE TORQUE** 80,000 ft-lb  
**REV/GAL AT FULL LOAD** 0.093  
**REV/GAL AT NO LOAD** 0.106

**DIFF. PRES.** 1090 psi

### STANDARD RUBBER

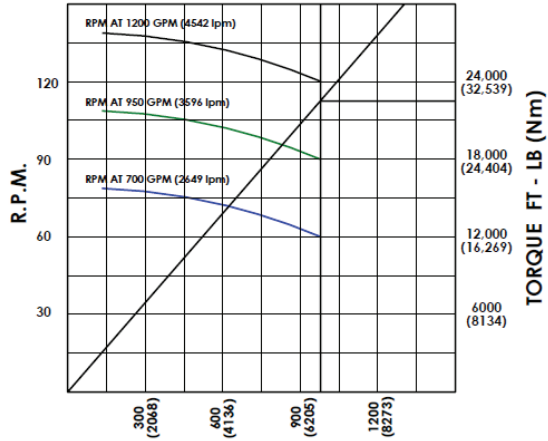

DIFFERENTIAL PRESSURE P.S.I. (kPa)

VOLUME (gpm)	700-1200
SPEED (rpm)	60-140
TORQUE AT FULL LOAD (ft-lb)	22500
OUTPUT AT FULL LOAD (hp)	515

### 11 1/4" 7 - 8 6.5 Stg

**MUD LUBE**  
 BIT TO BEND FIXED 79.4.1"  
 BIT TO BEND ADJ. 94.2"  
 MAX W.O.B. 153,300 lb.  
 O/A LENGTH 439.4"  
 MAX. OVERPULL AND RERUN 844,000 lb.  
 ABSOLUTE OVERPULL 2,019,633 lb.  
 TOOL SHIPPING WEIGHT 7857 lb.

**SEALED BEARING**  
 BIT TO BEND FIXED 87.2"  
 BIT TO BEND ADJ. 102.1"  
 MAX W.O.B. 240,000 lb.  
 O/A LENGTH 447.2"  
 MAX. OVERPULL AND RERUN 840,000 lb.  
 ABSOLUTE OVERPULL 1,510,000 lb.  
 TOOL SHIPPING WEIGHT 8116 lb.

**HOLE SIZE** 14 3/4" - 17 1/2"  
**BIT BOX CONN.** 7 5/8 REG.  
**ADJUSTABLE TORQUE** 80,000 ft-lb  
**REV/GAL AT FULL LOAD** 0.10  
**REV/GAL AT NO LOAD** 0.11

DIFF. PRES. 980 psi

11 1/4  
 7-8 6.5 Stg.



# Fishing Dimensions

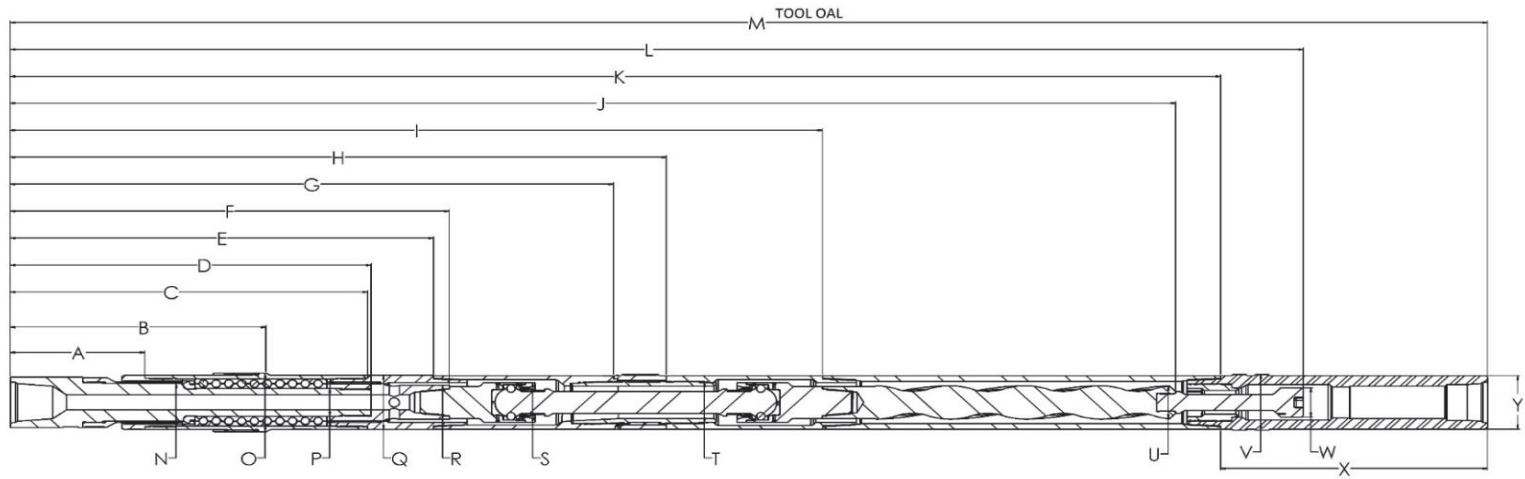

Mud Lube Fishing Dimensions

Motor	Lobes	Stages	A	B	C	D	E	F	G	H	I	J	K	L	M	N	O	P	Q	R	S	T	U	V	W	X	Y	
4 3/4	5-6	8.3	13.9	24.3	36	34.33	42	43	59.5	64.3	80.6	310	323	321.7	346	3.2	5.4	2.4	4.8	2.75	3.5	3.8	3	5	2.3	23	4.75	
4 3/4	7-8	2.6										301	310	323.6	333													
4 3/4	7-8	3.8										259	268	270.3	291													
5.00	6-7	8.0										15.2	314	327	325.8													350
6 1/4	7-8	3.3	14.7	27.9	38	36.2	43.1	46	63.7	69.7	87.4	339	347	355.6	379	4.2	7.1	3.1	6.3	4	4.5	4.9	4.2	6.6	3.1	32	6.3	
6 1/4	7-8	4.8										282	291	297.9	323								3.98					
6 1/2	4-5	7	16.6	29.7	43	41.75	48.1	51	69.7	75.6	95.1	298	309.7	313.8	340	4.4	7.1	3.3	6.6	4	5	5.1	4.2	6.8	3.1	30	6.50	
6 1/2	6-7	5										289	295.1	305.3	325								4.3					
6 1/2	7-8	2.9										316	323.9	332.1	354								4.20					
6 3/4	7-8	3.5										347	355.1	363.3	385								4.64					7
6 1/2	7-8	5										283	290	299.3	320								4.5					6.8
6 3/4	7-8	5.7										347	355	363.3	385								4.6					7
6 1/2	7-8	6										318	327	334.3	357								4.5					6.8
6 1/2	7-8	6										318	327	334.3	357								4.5					6.8
8.00	4-5	3.6	17.9	34	47.5	48	56.3	58	80.2	87.3	108	261	268	281.4	304	5.6	8.8	4.1	8.1	5	5.9	5.9	4.9	8.3	4.4	36	8	
8.00	7-8	3.4										401	408	428.4	444								5.3					
8.00	7-8	4.0										304.3	311.2	324.6	347								5.2					
962	5-6	4.0	22.8	43.1	54.6	54.6	64.8	70	92.6	101	124	342	354	361.9	389	9.5	10.9	5.2	9.6	5.9	6.6	7.3	5.5	9.6	4.4	35	9.6	

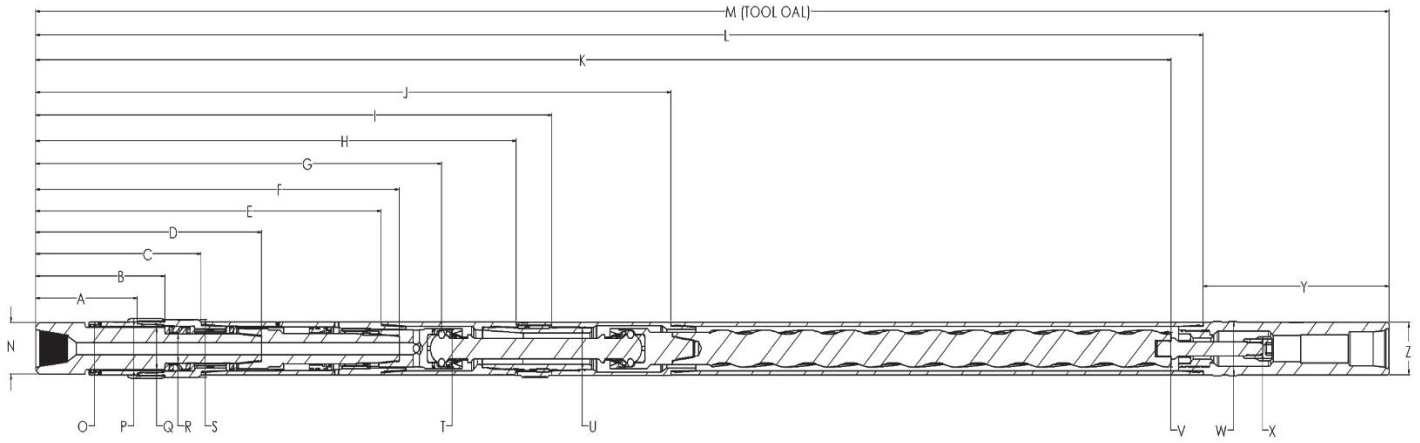

Sealed Bearing Fishing Dimensions

Motor	Lobes	Stages	A	B	C	D	E	F	G	H	I	J	K	L	M	N	O	P	Q	R	S	T	U	V	W	X	Y	Z																								
11/16	5-6	4.0	5.8	N/A	8.4	N/A	20.4	20.3	22.2	N/A	N/A	34.4	88.6	92	92	1.7	N/A	N/A	1.1	N/A	1.7	1.2	N/A	1.0	N/A	N/A	N/A	N/A																								
11/16	5-6	4.4											113.4	116.9	116.9									1.0																												
21/8	5-6	4.0	6.0	N/A	10.0	14.9	24.1	25.4	28.1	N/A	N/A	43.1	107.1	109.5	117.1	2.2	2.2	2.2	N/A	1	2.2	1.5	N/A	1.3	N/A	1.3	7.5	2.2																								
21/8	5-6	6.0											126.1	131.1	138.6									1.3																												
27/8	5-6	3.0	8.0	N/A	11.7	17.3	26.0	27.3	30.3	37.6	42.3	52.8	120	126.7	139.7	3.1	N/A	2.9	N/A	1.6	2.9	2.2	3.3	1.6	N/A	1.8	13	2.9																								
27/8	5-6	4.7											144.8	150.8	163.8									1.6																												
27/8	5-6	7.0											162.8	169.8	182.8									1.5																												
27/8	7-8	3.0											126.3	134.1	147.1									1.6																												
27/8	7-8	3.5											125.8	132.8	145.8									1.5																												
27/8	7-8	3.6											126.8	127.8	140.8									1.6																												
31/8	5-6	3.5											9.6	N/A	13.3									N/A					27.3	N/A	32.1	N/A	N/A	54.4	139.9	152.9	173.9	3.1	N/A	3.2	2.4	N/A	3.2	2.1	N/A	2.0	3.4	1.4	21.0	3.2		
31/8	5-6	5.0	174.4	187.4	208.4	2.0																																														
31/8	7-8	3.0	155.4	160.4	181.4	1.8																																														
33/4	3-4	9.0	9.2	N/A	13.2	20.1	31.2	33.7	37.5	44.9	49.8	60.8	186.8	209.8	230.8	3.4	3.7	3.7	2.5	2.1	N/A	2.6	2.7	2.0	4.0	1.5	21.0	3.7																								
33/4	5-6	3.8											134.8	141.3	162.3									1.9																												
33/4	7-8	6.7											323.8	240.8	261.8									2.0																												

43/4	4-5	3.6											199.6	207.6	230.6																				2.7								
43/4	4-5	5.4											255.6	279.6	302.6																				3.1								
43/4	5-6	3.0											164.1	171.1	194.1																					2.7							
43/4	5-6	8.3											309	322.1	345.1																					3.1							
43/4	6-7	2.5											237.6	261.6	284.6																					3.1							
43/4	7-8	2.6	11.6	15.6	18.9	26.6	41	43.5	48.2	58.6	63.4	79.6	299.6	308.9	331.9	4.6	4.8	5.4	3.7	2.5	5.4	3.4	3.7	2.7	5.0	2.3	23.0	4.7															
43/4	7-8	3.0											192.6	202.2	225.2																						2.7						
43/4	7-8	3.1											308.6	317.6	340.6																						2.7						
43/4	7-8	3.8											257.6	266.6	289.6																							2.7					
43/4	7-8	4.5											299.6	308.9	331.9																							2.7					
43/4	7-8	5.0											265.6	277.6	300.6																							3.1					
5.0	6-7	8.0	12.1	15.6	18.9	27.3	41.5	43.6	48.8	59.1	63.8	80.8	314.3	326.8	349.8	4.8	5.1	5.7	4	5.6	2.7	3.6	3.7	2.7	5.3	2.3	23.0	5.0															
61/4	7-8	3.0											284.5	298.5	330.5																							4.0					
61/4	7-8	3.3											346.5	354.5	386.5																							4.0					
61/4	7-8	3.8	14.4	18.9	24.1	33.7	50.1	52.7	58.7	70.7	76.7	94.5	386.3	394.3	426.3	6.2	6.3	7.1	5	3.5	6.8	4.5	4.9	4.0	6.5	3.1	32	6.3															
61/4	7-8	4.8											288.8	297.7	329.7																							3.5					
61/4	7-8	6.7											386.3	394.3	426.3																							4.0					

6 1/2	4-5	4.3	16.4	20.4	26.7	36.4	55.9	58.7	65.6	77.4	83.3	102.7	219.7	226.7	256.7	6.3	6.5	7.4	5.3	3.7	7.1	5.0	5.1	3.5	6.7	3.1	30	6.5
6 1/2	4-5	7.0											305.2	317.3	347.3									4.0				
6 1/2	6-7	2.7											308.2	332.7	362.7									4.7				
6 1/2	6-7	5.0											296.7	302.7	332.7									4.0				
6 1/2	7-8	2.9											323.5	331.5	361.5									4.0				
6 1/2	7-8	3.3											341.2	347.7	377.7									4.0				
6 1/2	7-8	4.8											297.0	306.2	336.2									3.5				
6 1/2	7-8	5.0											290.7	297.2	327.2									4.0				
6 1/2	7-8	6.0											325.7	334.7	364.7									4.5				
6 1/2	7-8	6.7											394.6	402.5	432.5									4.0				
6 3/4	5-6	6.8	16.4	20.8	26.7	36.40	55.9	58.7	65.6	77.4	83.4	102.7	324.7	329.7	359.7	6.3	6.5	7.4	5.3	3.7	7.1	5.0	5.1	4.1	7.0	3.1	30	6.8
6 3/4	6-7	2.9											279.7	304.7	334.7									4.7				
6 3/4	6-7	4.8											279.7	304.7	334.7									4.7				
6 3/4	7-8	3.3											341.2	347.7	377.7									4.0				
6 3/4	7-8	3.5											354.7	362.7	392.7									4.5				
6 3/4	7-8	5.7											354.7	362.7	392.7									4.5				
6 3/4	9-10	4.0											254.7	260.5	290.5									4.1				
8.00	4-5	3.6	20.9	25.8	30.9	42.8	65.6	69.4	76.5	89.5	96.5	117.1	270.1	277.1	312.6	7.8	8.0	8.7	6.7	4.7	8.7	5.9	6.1	4.7	8.3	4.3	35.5	8.0
8.00	5-6	5.2											345.1	357.1	392.6									4.7				
8.00	5-6	6.0											340.1	351.1	386.6									4.7				
8.00	7-8	3.0											270.1	277.1	312.6									4.7				
8.00	7-8	3.4											410.1	417.1	449.6									4.7				
8.00	7-8	4.0											313.4	320.3	355.8									4.7				
8.00	9-10	3.0	340.1	351.1	386.6	4.7																						

11 1/4	3-4	3.6	21.9	31.3	33.9	48.2	74.8	77.5	87.8	102	110.3	133.7	326.2	338.7	381.2	10.5	11.3	12.3	9	7.1	12.3	6.6	8.9	6.5	11.3	4.4	42.5	11.3	
11 1/4	5-6	4.6											6.5																
11 1/4	6-7	3.5											5.9																
11 1/4	6-7	5.5											6.5																
11 1/4	7-8	4.8											5.5																
11 1/4	7-8	6.5											5.5																
													423.7	433.7	476.2														